



RSPile

Laterally Loaded Piles

Theory Manual

Table of Contents

1. Soil Response Modelled by p-y curves	3
2. Governing Differential Equation.....	4
3. Finite Element Method.....	6
4. Pile Bending Stiffness	6
5. Soil Models	7
5.1. p-y curves for soft clay with free water (Matlock, 1970)	7
5.2. p-y curves for stiff clay with free water (Reese et al., 1975)	8
5.3. p-y curves for stiff clay without free water (Welch & Reese, 1972).....	10
5.4. p-y curves for sand above and below water (Reese et al., 1974).....	11
5.5. p-y curves for weak rock (Reese & Nyman, 1978)	12
5.6. Elastic Soil Model	13
5.7. User Defined Soil Model.....	13
5.8. p-y curves for API Method for sand (API RP 2A)	14
5.9. p-y curve for Loess soil (Johnson, et al., 2006)	15
5.10. p-y curve for liquified sand (Rollins et al., 2005a)	16
5.11. p-y curve for piedmont residual soils (Simpson & Brown, 2003)	17
5.12. p-y curve for strong rock (vuggy limestone) (Reese & Nyman, 1978)	19
5.13. p-y curve for modified stiff clay without free water (Welch & Reese, 1972).....	19
5.14. p-y curve for silt (cemented c-phi soil) (Reese et al., 1974).....	20
5.15. p-y curve for hybrid liquefied sand (Frank and Rollins, 2013 & Wang and Reese, 1998)	22
5.16. p-y curve for massive rock (Liang, Yang, and Nusairat, 2009)	25
6. Layered Soil Profile: Method of Georgiadis	27
7. Ground Slope and Pile Batter	27
8. References.....	29

1. Soil Response Modelled by p-y curves

In order to properly analyze a laterally loaded pile foundation in soil/rock, a nonlinear relationship needs to be applied that provides soil resistance as a function of pile deflection. The drawing in Figure 1.1a shows a cylindrical pile under lateral loading. Unloaded, there is a uniform distribution of unit stresses normal to the wall of the pile as shown in Figure 1.1b. When the pile deflects a distance of y_1 at a depth of z_1 , the distribution of stresses looks similar to Figure 1.1c with a resisting force of p_1 : the stresses will have decreased on the backside of the pile and increased on the front, where some unit stresses contain both normal and shearing components as the displaced soil tries to move around the pile.

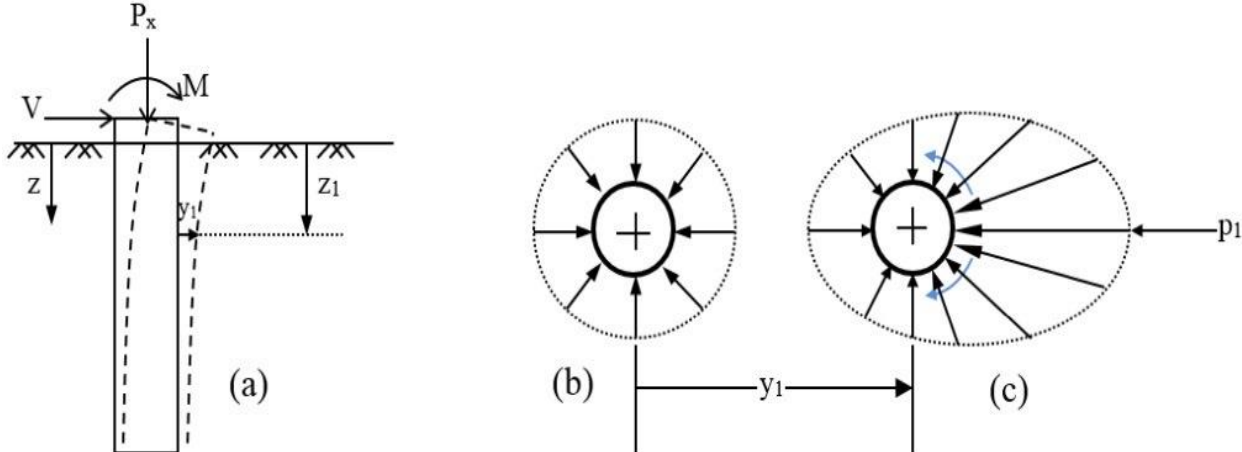

Figure 1.1: Unit stress distribution in a laterally loaded pile

When it comes to this type of analysis, the main parameter to take from the soil is a reaction modulus. It is defined as the resistance from the soil at a point along the depth of the pile divided by the horizontal deflection of the pile at that point. **RSPile** defines this reaction modulus (E_{py}) using the secant of the p-y curve, as shown in Figure 1.2. p-y curves are developed at specific depths, indicating the soil reaction modulus is both a function of pile deflection (y) and the depth below the ground surface (z). More information will be given on the p-y curves used in a later section.

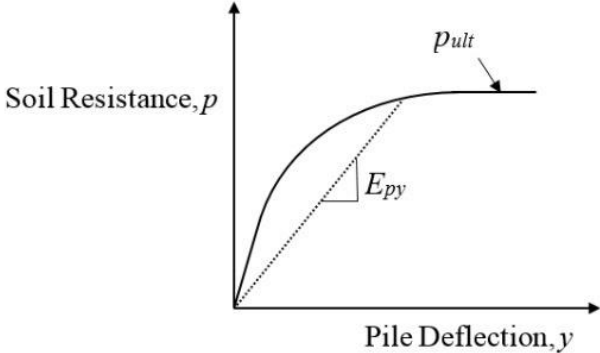

Figure 1.2: Generic p-y curve defining soil reaction modulus

2. Governing Differential Equation

The differential equation for a beam-column, as derived by Hetenyi (1946), must be solved for implementation of the p-y method. The conventional form of the differential equation is given by Equation 1:

$$(1) \quad E_p I_p \frac{d^4 y}{dx^4} + P_x \frac{d^2 y}{dx^2} + E_{py} y - W = 0$$

where y = Lateral deflection of the pile
 $E_p I_p$ = Bending stiffness of pile
 P_x = Axial load on pile head
 E_{py} = Soil reaction modulus based on
 W = Distributed load down some length of the pile

Further formulas are given by Equations 2 – 4:

$$(2) \quad E_p I_p \frac{d^3 y}{dx^3} + P_x \frac{dy}{dx} = V$$

$$(3) \quad E_p I_p \frac{d^2 y}{dx^2} = M$$

$$(4) \quad \frac{dy}{dx} = S$$

where V = Shear in the pile
 M = Bending moment of the pile
 S = Slope of the curve defined by the axis of the pile

In the case where the pile is loaded by laterally moving soil, the soil reaction is determined by the relative soil and pile movement. This requires a change to the third term of Equation 1 given by Equation 5:

$$(5) \quad E_{py}(y - y_{soil}) = M$$

The modified form of the differential equation now becomes

$$(6) \quad E_p I_p \frac{d^4 y}{dx^4} + P_x \frac{d^2 y}{dx^2} + E_{py}(y - y_{soil}) - W = 0$$

where soil reaction modulus (E_{py}) is found from the p-y curve using the relative pile soil movement ($y - y_{soil}$) instead of only the pile deflection (y).

Using a spring-mass model in which springs represent material stiffness, numerical techniques can be employed to conduct the load-deflection analysis (Figure 2.1). A moment, shear, axial, and soil movement load are also shown.

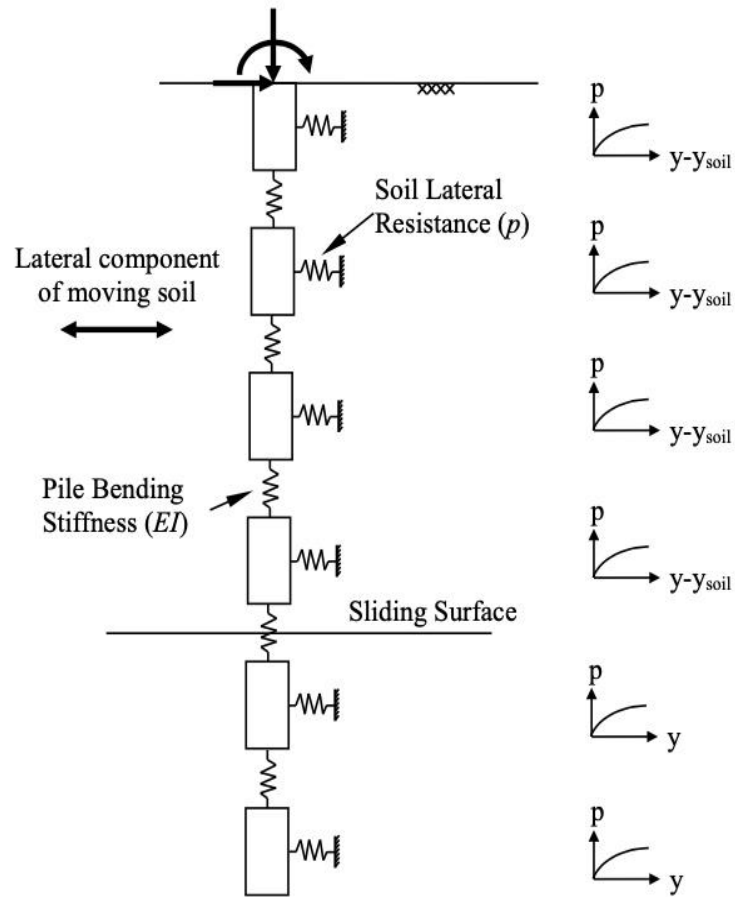

Figure 2.1: Spring mass model used to compute lateral response of loaded piles

3. Finite Element Method

The **RS3** finite element beam engine is employed in **RSPile**. The piles are formulated as line components. The beams are formulated on the assumption of Timoshenko beams (Cook et al, 2002) which considers shear stresses on their cross-sectional area.

4. Pile Bending Stiffness

For elastic piles, the stiffness of each pile node ($E_p I_p$) is calculated by multiplying the elastic modulus by the moment of the inertia of the pile. In analyzing a plastic pile, the yield stress of the steel is required from the user. Currently, plastic analyses can be performed on uniform cylindrical, rectangular, and pipe piles. The analysis is done by performing a balance of forces (tension and compression) in n slices of the pile cross section parallel to the bending axis. This is done at many different values of bending curvature (ϕ). When the forces in the slices balance around the neutral axis, the moment can be computed. Equation 7 and 8 are used in order to find the bending stiffness based on the moment and curvature.

$$(7) \quad \varepsilon = \phi \eta$$

$$(8) \quad EI = \frac{M}{\phi}$$

- where ε = Bending Strain
 ϕ = Bending curvature
 η = Distance from the neutral axis
 M = Bending moment of the pile

The stiffness of the pile is then checked against the moment value at the node for each iteration. The relation between moment and stiffness will look like Figure 4-1. As shown, the stiffness remains in the elastic range until yielding occurs, usually at a fairly high moment value.

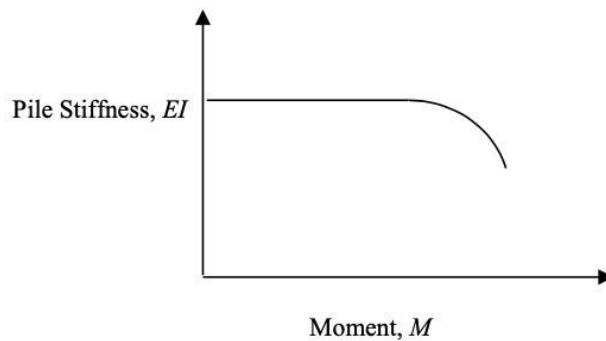

Figure 4.1: Generic stiffness vs. moment curve for a steel pile

5. Soil Models

Recommendations are presented for obtaining p-y curves for clay, sand, and weak rock. All are based on the analysis of the results of full-scale experiments with instrumented piles. Selection of soil models (p-y curves) to be used for a particular analysis is the most important problem to be solved by the engineer. Some guidance and specific suggestions are presented in the text, *Single Piles and Pile Groups Under Lateral Loading, 2nd Edition*, by L. Reese and W. Van Impe. This book also provided the tables presented in the different types of soil that follow.

A list of the variables used in the equations that follow can be found below:

b	=	diameter of the pile (m)
z	=	depth below ground surface (m)
γ'	=	effective unit weight (kN/m ³)
J	=	factor determined experimentally by Matlock equal to 0.5
c_u	=	undrained shear strength at depth z (kPa)
c_a	=	average undrained shear strength at depth z (kPa)
φ	=	undrained shear strength at depth z (kPa)

5.1. p-y curves for soft clay with free water (Matlock, 1970)

To complete the analysis for soft clay, the user must obtain the best estimate of the undrained shear strength and the submerged unit weight. Additionally, the user will need the strain corresponding to one-half the maximum principal stress difference ϵ_{50} . Some typical values of ϵ_{50} are given in Table 5.1 according to undrained shear strength.

Table 5.1: Representative values of ϵ_{50} for normally consolidated clays

Consistency of Clay	Average undrained shear strength (kPa)*	ϵ_{50}
Soft	<48	0.020
Medium	48-96	0.010
Stiff	96-192	0.005

*Peck et al. 1974, pg. 20.

The development of the p-y curve for soft clay is presented in Figure 5.1.

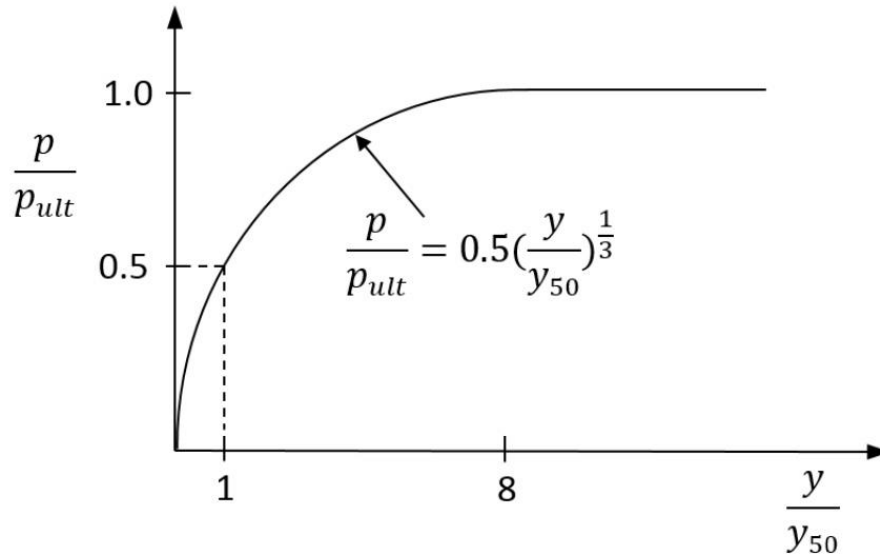

Figure 5.1: p-y curve for Soft Clay

p_{ult} is calculated using the smaller of the values given by the equations below.

$$(9) \quad p_{ult} = \left[3 + \frac{\gamma' z}{c_u} + \frac{J}{b} z \right] c_u b$$

$$(10) \quad p_{ult} = 9c_u b$$

The Soft Clay Soil material in RSPile assumes a default value of $J = 0.5$. The Soft Clay with User Defined J material allows users to enter custom J values.

5.2. p-y curves for stiff clay with free water (Reese et al., 1975)

The analysis of stiff clay with free water requires the same inputs as soft clay as well as the value k_s with some representative values presented in Table 5.3. Typical values of ϵ_{50} according to undrained shear strength can be found in Table 5.2.

Table 5.2: Representative values of ϵ_{50} for overconsolidated clays

Average undrained shear strength (kPa)*	50-100	100-200	200-400
ϵ_{50}	0.007	0.005	0.004

Table 5.3: Representative values of k_{py} for overconsolidated clays

Average undrained shear strength (kPa)*	50-100	100-200	200-400
k_{py} (static) MN/m ³	135	270	540
k_{py} (cyclic) MN/m ³	55	110	540

*The average shear strength should be computed from the shear strength of the soil to a depth of 5 pile diameters. It should be defined as half the total maximum principal stress difference in an unconsolidated undrained triaxial test.

The development of the p-y curve for submerged stiff clay is presented in Figure 5.2. As is a coefficient based on the depth to diameter ratio according to Figure 5.3, and the variable k_s mentioned above is used to define the initial straight-line portion of the p-y curve.

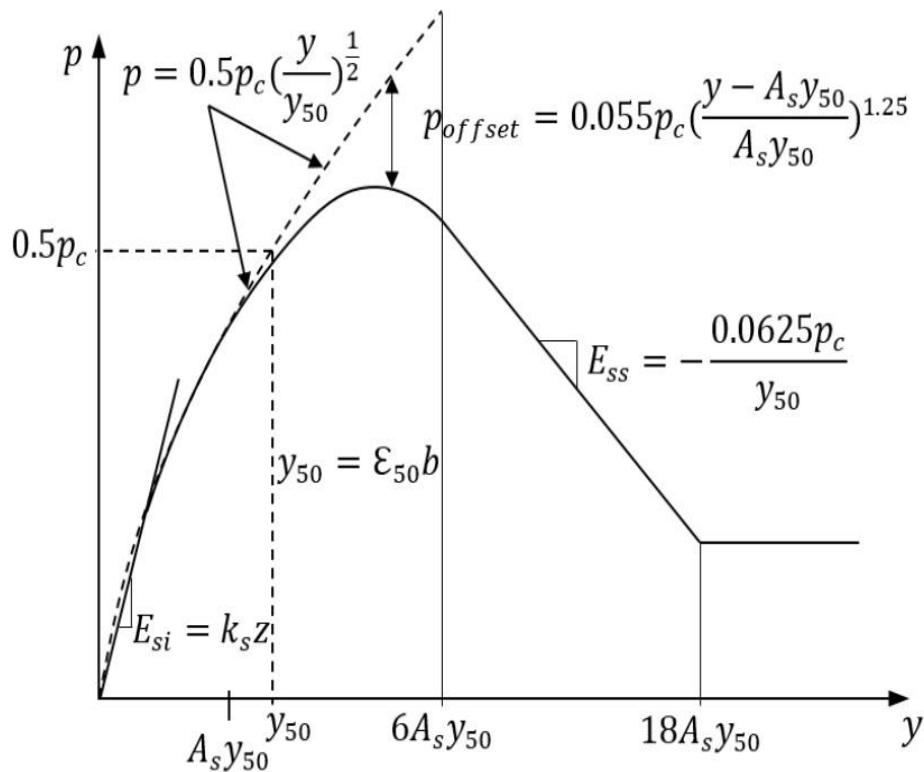

Figure 5.2: p-y curve for Stiff Clay with water

p_c is calculated using the smaller of the values given by the equations below.

$$(11) \quad p_c = 2c_a b + \gamma' b z + 2.83c_a z$$

$$(12) \quad p_c = 11c_u b$$

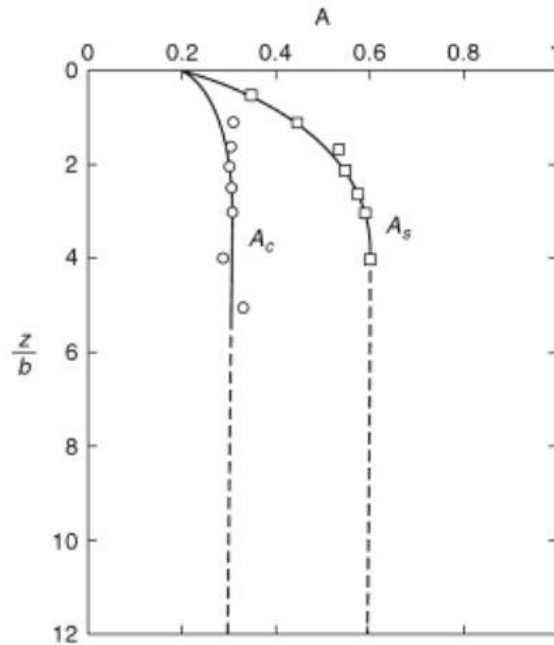

Figure 5.3: Values of constants A_s and A_c (Reese & Van Impe, 2011)

5.3. p-y curves for stiff clay without free water (Welch & Reese, 1972)

The input parameters for stiff clay without free water are the same as for soft clay, but the soil unit weight will not be submerged and the value for ϵ_{50} , should you not have an available stress-strain curve, should be 0.01 or 0.005 as given in Table 5.2. The larger value is more conservative.

The development of the p-y curve for dry stiff clay is presented in Figure 5.4.

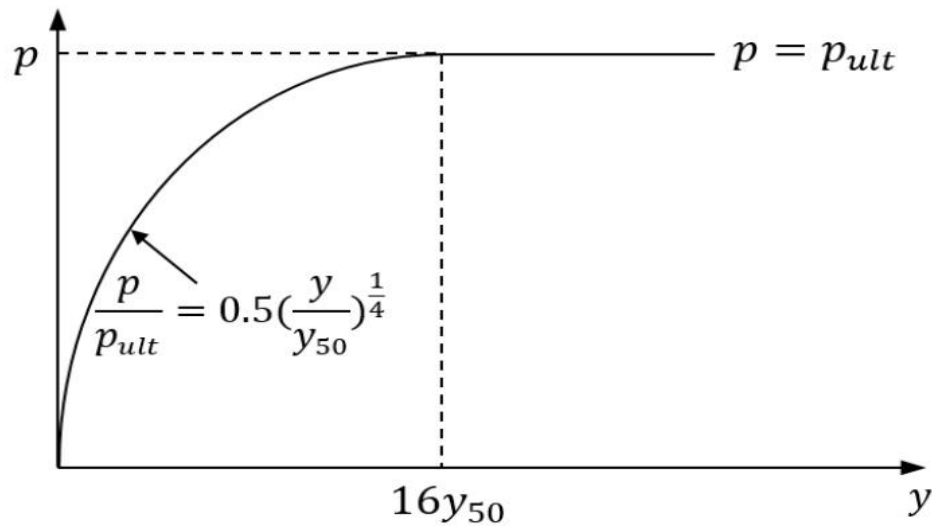

Figure 5.4: p-y curve for Stiff Clay without water

p_{ult} is calculated using the smaller of the values given by the equations below.

$$(13) \quad p_{ult} = \left[3 + \frac{\gamma'}{c_a} z + \frac{I}{b} z \right] c_a b$$

$$(14) \quad p_{ult} = 9c_u b$$

5.4. p-y curves for sand above and below water (Reese et al., 1974)

To achieve a p-y curve for sand, the user must obtain values for the friction angle, soil unit weight (buoyant unit weight for sand below; and total unit weight for sand above the water table). The value k_{py} is also required and some values are given in Table 5.4 and Table 5.5.

Table 5.4: Representative values of k_{py} for submerged sand

Relative Density	Loose	Medium	Dense
Recommended k_{py} (MN/m ³)	5.4	16.3	34

Table 5.5: Representative values of k_{py} for sand above the water table (Static and Cyclic)

Relative Density	Loose	Medium	Dense
Recommended k_{py} (MN/m ³)	6.8	24.4	61

The development of the p-y curve for sand is presented in Figure 5.5. The variable k_{py} mentioned above is used to define the initial straight line portion of the p-y curve. The soil resistance, p_k , and pile deflection, y_k , are calculated from p_m , p_u , y_m , and y_u . If y_k is greater than y_u then the p-y curve is linear from the origin to y_u , p_u .

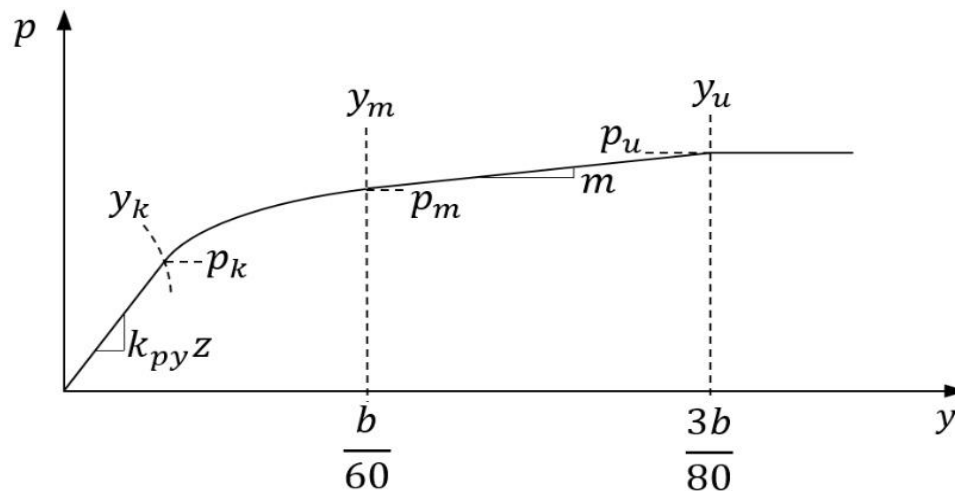

Figure 5.5: p-y curve for Sand

p_u and p_m are calculated using the smaller of the values given by p_s in the equations below, multiplied by coefficients A and B from Figure 5.6.

$$\alpha = \frac{\varphi}{2}, \beta = 45 + \frac{\varphi}{2}, K_0 = 0.4, K_a = \tan^2 \left(45 - \frac{\varphi}{2} \right)$$

$$(15) \quad p_s = \gamma z \left[\frac{K_0 z \tan \varphi \sin \beta}{\tan(\beta - \varphi) \cos \alpha} + \frac{\tan \beta}{\tan(\beta - \varphi)} (b + z \tan \beta \tan \alpha) + K_0 z \tan \beta (\tan \varphi \sin \beta - \tan \alpha) - K_a b \right]$$

$$(16) \quad p_s = K_a b \gamma z (\tan^3 \beta - 1) + K_0 b \gamma z \tan \varphi \tan^4 \beta$$

$$p_u = \bar{A}_s p_s, p_u = B_s p_s$$

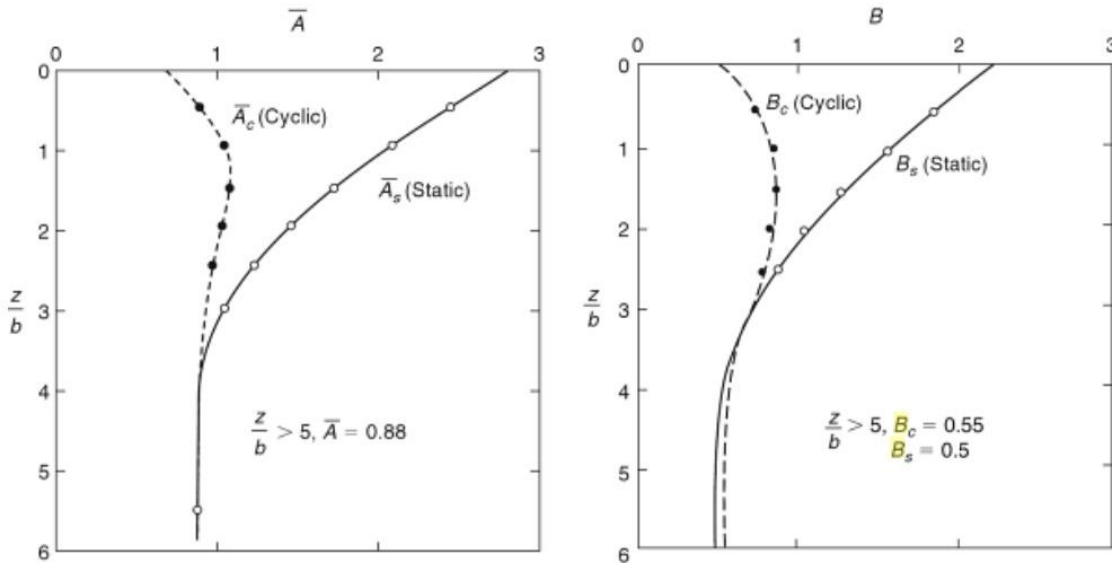

Figure 5.6: Coefficients for soil resistance versus depth (Reese & Van Impe, 2011)

5.5. p-y curves for weak rock (Reese & Nyman, 1978)

For the design of piles under lateral loading in rock, special emphasis is necessary in the coring of the rock. Designers must address the potential weakness of the rock in a case-by-case manner, therefore reliance on the method presented is limited. When it comes to intermediate materials (rock and strong soil), designers may wish to compare analysis performed by stiff clay and this method. It is noted that bending stiffness of the pile must reflect non-linear behavior in order to predict loadings at failure.

The input parameters required for this method are, uniaxial compressive strength, reaction modulus of rock, the rock quality designation (percent of recovery), and a strain factor k_{rm} ranging from 0.0005 to 0.00005. k_{rm} can be taken as the compression strain at fifty percent of the uniaxial compressive strength.

The development of the p-y curve for weak rock is presented in Figure 5.7. The ultimate resistance for rock, p_{ur} , is calculated from the input parameters. The linear portion of the curve with slope K_{ir} defines the curve until intersection with the curved portion defined in the figure.

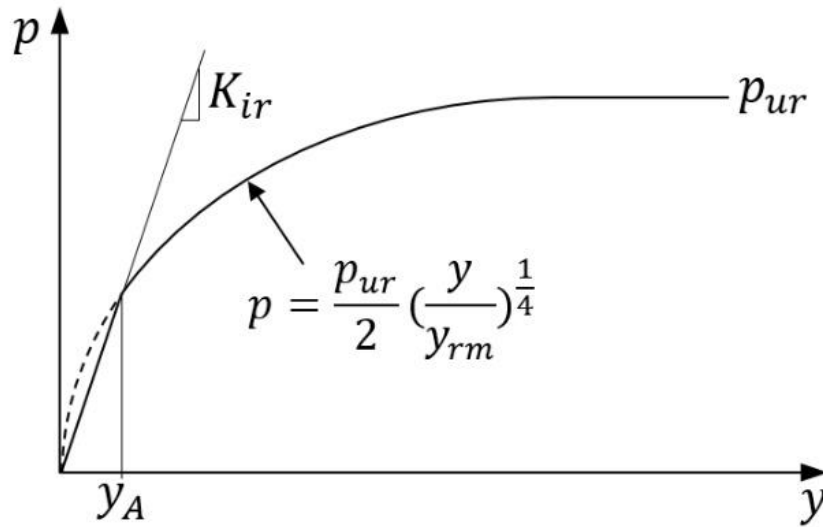

Figure 5.7: p-y curve for Weak Rock

p_{ur} is calculated using the smaller of the values given by the equations below.

$$a_r = 1 - \left(\frac{2 RQD\%}{3 \cdot 100\%} \right)$$

$$(17) \quad p_{ur} = a_r q_{ur} b \left(1 + 1.4 \frac{z_r}{b} \right)$$

$$(18) \quad p_{ur} = 5.2 a_r q_{ur} b$$

5.6. Elastic Soil Model

An elastic soil material has infinite strength and can easily be defined using the elastic soil reaction. The Elastic Subgrade Reaction describes the lateral soil pressure in response to a unit of soil displacement. The elastic soil reaction is multiplied by the diameter of the pile to get the soil reaction modulus used in the analysis.

5.7. User Defined Soil Model

A user defined soil model allows the user to input the soil resistance for various soil deflection values to define the p-y curve. The soil resistance is in units of force per length of pile segment while the deflection is in length units. When the soil deflection exceeds the last (maximum) entered deflection value, the soil resistance is assumed to be the last entered resistance.

5.8. p-y curves for API Method for sand (API RP 2A)

To develop the p-y curve for API Sand the friction angle and initial modulus of subgrade reaction is required.

The development for the p-y curve for API Sand is presented in Figure 5.8. The same procedure is used for both short-term static and cyclic loading.

At a given depth, p_u is taken as the lesser of the calculated p_{us} , at shallow depths, and p_{ud} , at larger depths:

$$(19) \quad p_{us} = (C_1 z + C_2 b) \gamma' z$$

$$(20) \quad p_{ud} = C_3 b \gamma' z$$

where p_{us} = resistance at shallow depths

p_{ud} = resistance at greater depths

and

$$(21) \quad C_1 = \tan \beta \left\{ K_p \tan \alpha + K_0 \left[\tan \phi \sin \beta \left(\frac{1}{\cos \alpha} + 1 \right) - \tan \alpha \right] \right\}$$

$$(22) \quad C_2 = K_p - K_A$$

$$(23) \quad C_3 = K_p^2 (K_p + K_0 \tan \phi) - K_A$$

where $K_0 = 0.4$ and

$$(24) \quad K_p = \tan^2 \left(45^\circ + \frac{\phi}{2} \right)$$

The p-y curve is computed based on p_u as follows:

$$(25) \quad p = A p_u \tanh \left(\frac{kx}{A p_u} y \right)$$

where A = static or cyclic loading factor (0.9 for cyclic; $(3 - 0.8 \frac{x}{b}) \geq 0.9$ for static)

k = initial modulus of subgrade reaction (user input)

ϕ = internal friction angle

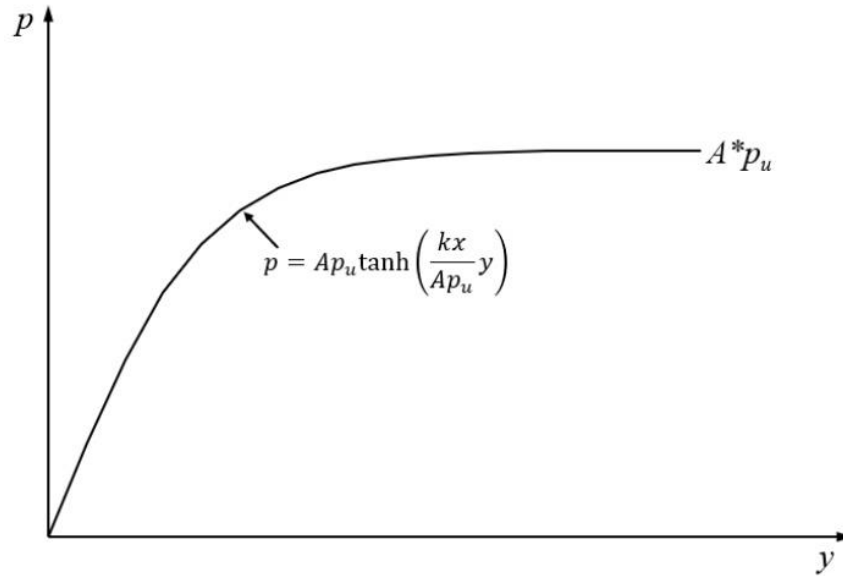

Figure 5.8: p-y curve for API sand

5.9. p-y curve for Loess soil (Johnson, et al., 2006)

The development of the p-y curve for soft clay is presented in Figure 5.9.

A secant modulus is used to determine the p value for a given deflection. First, the ultimate lateral resistance, p_{u0} (F/L^2), and ultimate lateral resistance adjusted for pile diameter, p_u (F/L), are calculated:

$$(26) \quad p_{u0} = N_{CPT} * q_c$$

$$(27) \quad p_u = \frac{p_{u0}b}{1 + C_n \log N}$$

where N_{CPT} = cone bearing capacity factor (dimensionless constant = 0.409)
 q_c = input CPT value (F/L^2)
 C_n = dimensionless constant (=0.24)
 N = number of cycles for cyclic loading (equal to 1 for static loading)

Next, the initial, E_i , and secant, E_s , modulus are calculated. Both have units of F/L^2 . The soil resistance is calculated from the secant modulus and lateral pile displacement.

$$(28) \quad E_i = \frac{p_u}{y_{ref}}$$

$$(29) \quad y_h = \left(\frac{y}{y_{ref}} \right) \left[1 + a * \exp \left(- \frac{y}{y_{ref}} \right) \right]$$

$$(30) \quad E_s = \frac{E_i}{(1+y_h)}$$

$$(31) \quad p = E_s y$$

where y_h = hyperbolic function of the reference displacement and lateral pile displacement (dimensionless)

a = dimensionless constant (=0.1)

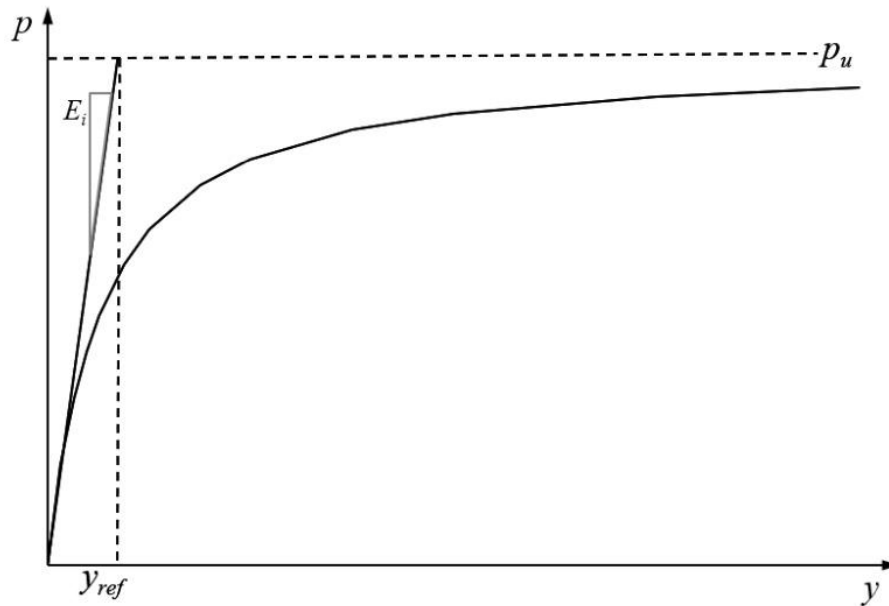

Figure 5.9: p-y curve for Loess soil

5.10. p-y curve for liquified sand (Rollins et al., 2005a)

The formulation in Rollins is based on a set of fully-instrumented load tests, and does not require any user input parameters.

The soil resistance, p (kN/m), is calculated as:

$$(32) \quad p = P_d A (By)^c$$

where

$$(33) \quad P_d = 3.81 \ln|b| + 5.6$$

$$(34) \quad A = 3 \times 10^{-7} (z + 1)^{6.05}$$

$$(35) \quad B = 2.80(z + 1)^{0.11}$$

$$(36) \quad C = 2.85(z + 1)^{-0.41}$$

and

P_d = diameter correction

Note that Equation 32 is limited in applicability between diameters of 0.3 to 2.6m. For diameters greater than 2.6m, a diameter of 2.6m is used. The development of the p-y curve for liquefied sand is presented in Figure 5.10.

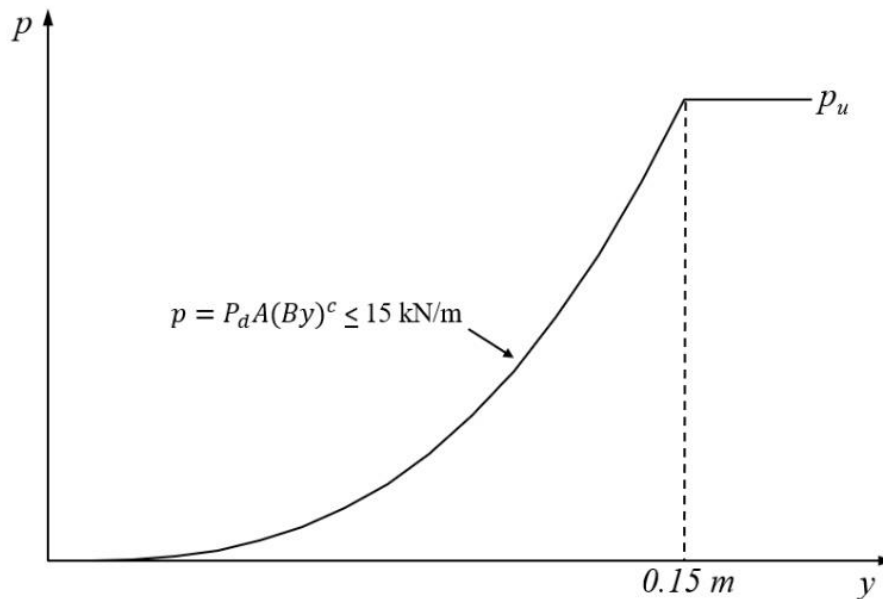

Figure 5.10: p-y curve for liquefied sand

5.11. p-y curve for piedmont residual soils (Simpson & Brown, 2003)

Four different input types are available for test values:

- Dilatometer Modulus (kPa)
- Cone Penetration Tip Resistance (kPa)
- Standard Penetration Blow Count (blows/cm)
- Menard Pressuremeter Modulus (kPa)

The initial soil modulus, E_{si} , is calculated as follows from each of the input value types. For the metric unit system, the modulus is calculated in kPa/m; for imperial the modulus is calculated in psf/ft.

$$E_{si} = \text{input factor} \times \text{user input value} \times \text{unit conversion factor}$$

Test Value Type	Input Factor
Dilatometer Modulus	0.076
Cone Penetration Tip Resistance	0.118
Standard Penetration Blow Count	22
Menard Pressuremeter Modulus	0.235

p values are calculated as follows:

For $\frac{y}{b} < 0.001$

$$(37) \quad p = ybE_{si}$$

For $0.001 \leq \frac{y}{b} \leq 0.0375$

$$(38) \quad p = by * E_{si} \left(1 - \lambda \ln \left| \frac{y/b}{0.001} \right| \right)$$

For $\frac{y}{b} > 0.0375$

$$(39) \quad p = (0.0375b) * b * E_{si} (1 - \lambda \ln 37.5)$$

The development of the p - y curve for piedmont residual soils is presented in Figure 5.11.

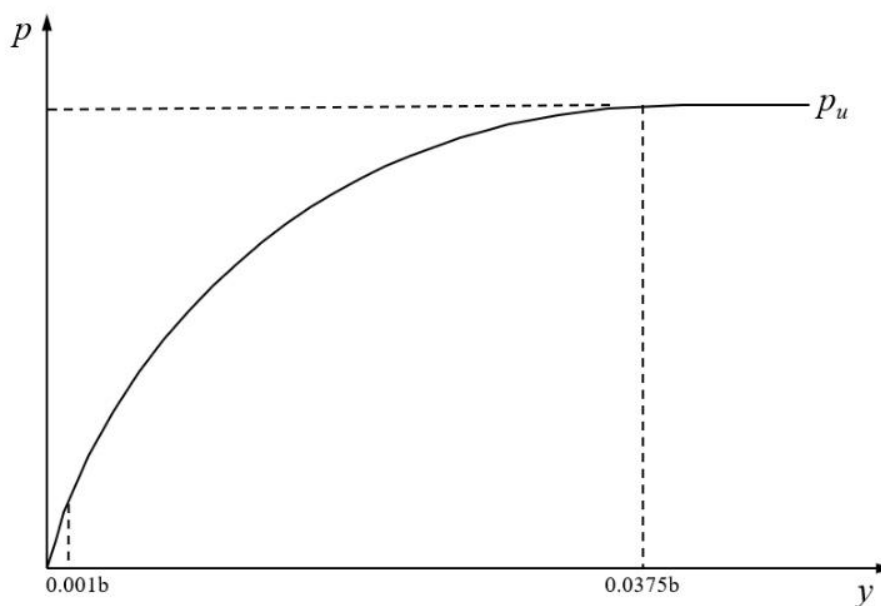

Figure 5.11: p - y curve for piedmont residual soils

5.12. p-y curve for strong rock (vuggy limestone) (Reese & Nyman, 1978)

The recommended curve for strong rock was developed based on field tests on instrumented drilled shafts in vuggy limestone. The development of the p-y curve for strong rock is presented in Figure 5.12.

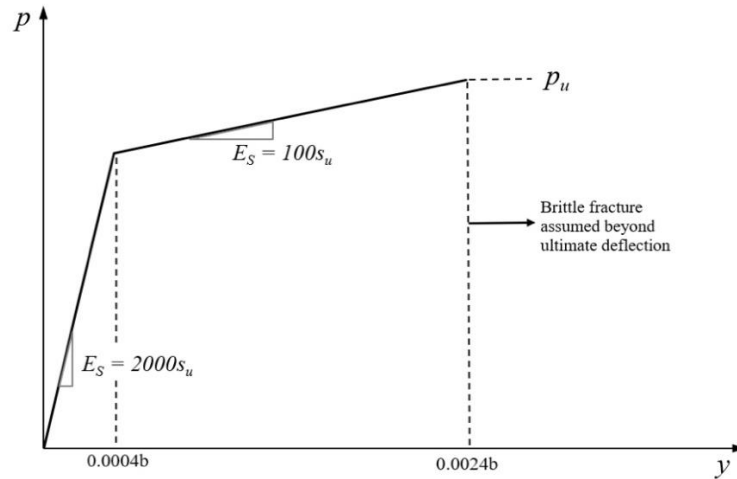

Figure 5.12: p-y curve for strong rock (vuggy limestone)

5.13. p-y curve for modified stiff clay without free water (Welch & Reese, 1972)

The formulation for modified stiff clay without free water introduces an initial stiffness to modify the p-y curves of the Dry Stiff Clay. **RSPile** uses the minimum of the p values calculated using the input initial stiffness and the equation for Dry Stiff Clay.

The development of the p-y curve for modified stiff clay without free water is presented in Figure 5-13. The development of the cyclic p-y curve is presented in Figure 5.14.

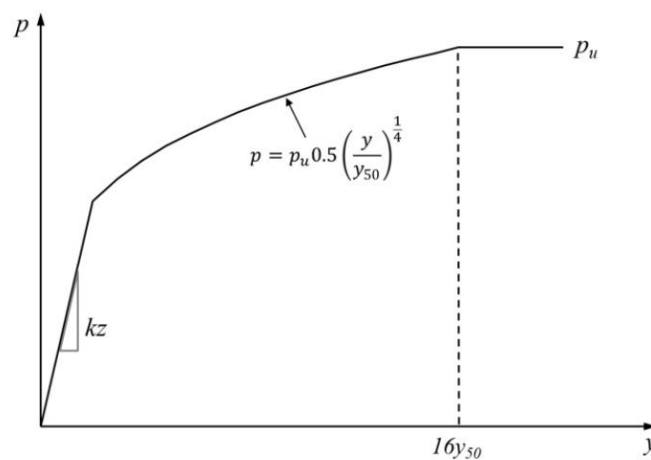

Figure 5.13: p-y curve for modified stiff clay without free water (static)

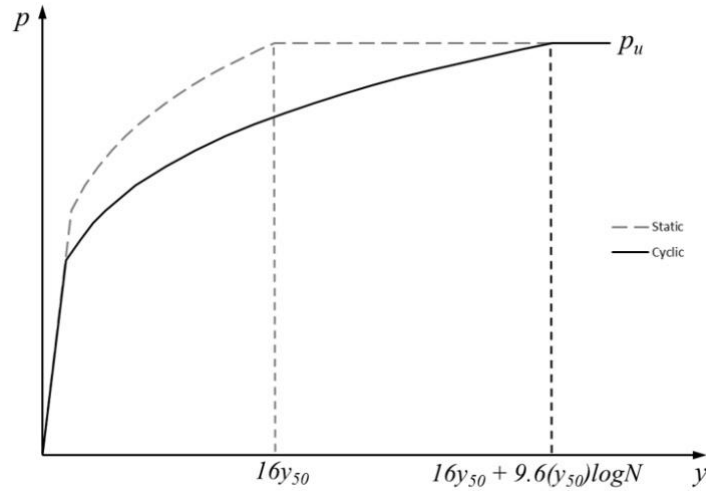

Figure 5.14: p-y curve for modified stiff clay without free water (cyclic)

5.14. p-y curve for silt (cemented c-phi soil) (Reese et al., 1974)

The development of the p-y curve for soft clay is presented in Figure 5.15. The curve for silt can contain four sections.

- Initial linear section between the origin and point k , with slope k_{pyz}

$$(40) \quad p = k_{pyz}y$$

where k_{py} = initial stiffness (user input)

- Parabolic section between points k and m

$$(41) \quad p = Cy^{1/n}$$

where n is a curve-fit parameter.

- Linear section between points m and u , with slope m

$$(42) \quad p = p_m + m(y - y_m)$$

- Flash section past point u

$$(43) \quad p = p_u$$

The main points on the p-y curve are calculated as shown below.

$$(44) \quad y_k = \left(\frac{c}{k_{pyz}} \right)^{\frac{n}{n-1}}$$

$$(45) \quad y_m = \frac{b}{60}$$

$$(46) \quad y_u = \frac{3b}{80}$$

$$(47) \quad p_m = 1.5p_\phi + p_c$$

$$(48) \quad p_u = \bar{A}p_\phi$$

where the frictional component is calculated as:

$$(49) \quad p_{\phi st} = \gamma z \left[\frac{K_0 z \tan \phi \sin \beta}{\tan(\beta - \phi) \cos \alpha} + \frac{\tan \beta}{\tan(\beta - \phi)} (b + z \tan \beta \tan \phi) \right. \\ \left. + K_0 z \tan \beta (\tan \phi \sin \beta - \tan \alpha) - K_A b \right] \\ p_{\phi d} = K_A b \gamma z (\tan^8 \beta - 1) + K_0 b \gamma z \tan \phi \tan^4 \beta \\ p_{u\phi} = \min(p_{\phi st}, p_{\phi d})$$

and the cohesive component is calculated as:

$$(50) \quad p_{cs} = \left(3 + \frac{\gamma}{c} z + \frac{1}{b} z \right) cb$$

$$p_{cd} = 9cb$$

$$p_{uc} = \min(p_{cs}, p_{cd})$$

$$K_0 = 0.4 \text{ (constant)}$$

$$\beta = \pi/4 + \phi/2$$

$$\alpha = \phi/2$$

$$K_A = \tan^2(\pi/4 - \phi/2)$$

$$\bar{A} = \text{coefficient for static or cyclic loading}$$

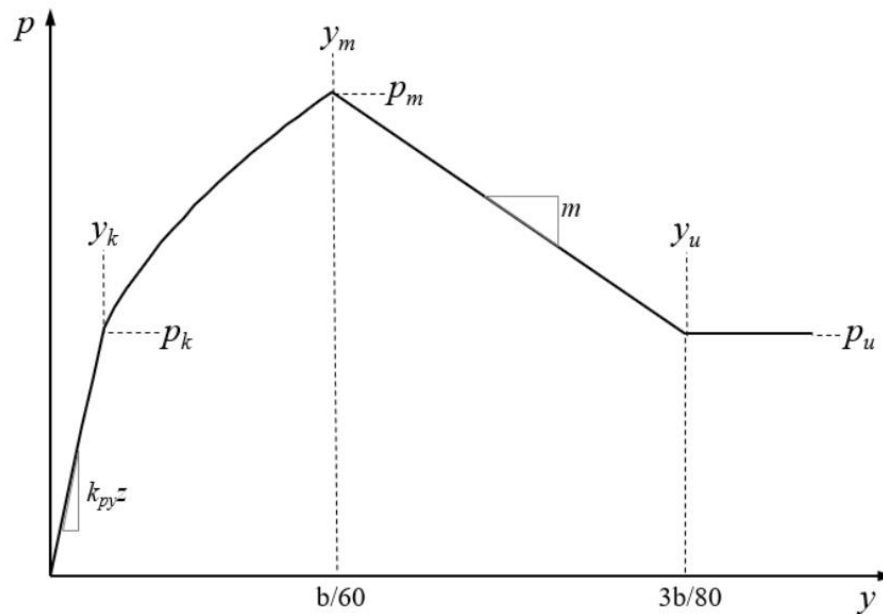

Figure 5.15: p-y curve for silt (cemented c-phi soil)

5.15. p-y curve for hybrid liquefied sand (Frank and Rollins, 2013 & Wang and Reese, 1998)

The Hybrid Liquefied Sand curves are based on Frank and Rollins (2013) and Wang and Reese (1998), where the lower resistance is taken.

There are four possible patterns of overlap for the dilative, liquefied sand, and residual, soft clay, curves. For each point, the ultimate lateral resistance for clay and liquefied sand is calculated and **RSPile** outputs the overall curve. The development of the p-y curve for hybrid liquefied sand is presented in Figure 5.16 through Figure 5.19.

$$(51) \quad p = \min(p_{\text{clay}}, p_{\text{liq}})$$

p_{clay} is calculated as:

$$(52) \quad p_{u, \text{clay}} = \min \left[\left(3 + \frac{\gamma'_{\text{avg}}}{c} z + \frac{J}{b} z \right) cb, 9cb \right]$$

$$(53) \quad p_{\text{clay}} = p_{u, \text{clay}} \text{ for } y > 8y_{50}$$

$$p_{\text{clay}} = \frac{p_{u, \text{clay}}}{2} \left[\frac{y}{y_{50}} \right]^{\frac{1}{3}} \text{ for } y \leq 8y_{50}$$

where

$$\begin{aligned} J &= 0.5 \\ y_{50} &= 2.5\epsilon_{50}b \end{aligned}$$

p_{liq} is calculated as:

$$(54) \quad p_{u, \text{liq}} = \min[p_d A (150B)^C, p_d p_{\text{max}}]$$

where

$$(55) \quad p_d = \frac{b}{0.3m \text{ for } b} < 0.3m$$

$$p_d = 3.81 \ln|b| + 5.6 \text{ for } 0.3 \leq b \leq 2.6m$$

$$p_d = 3.81 \ln(2.6) + 5.6 \text{ for } b > 2.6m$$

$$(56) \quad A = 3 \times 10^{-7} (z + 1)^{6.05}$$

$$B = 2.80 (z + 1)^{0.11}$$

$$C = 2.85 (z + 1)^{-0.41}$$

$$(57) \quad p_{\text{liq}} = m [p_{u, \text{liq}}, p_d A (By)^C]$$

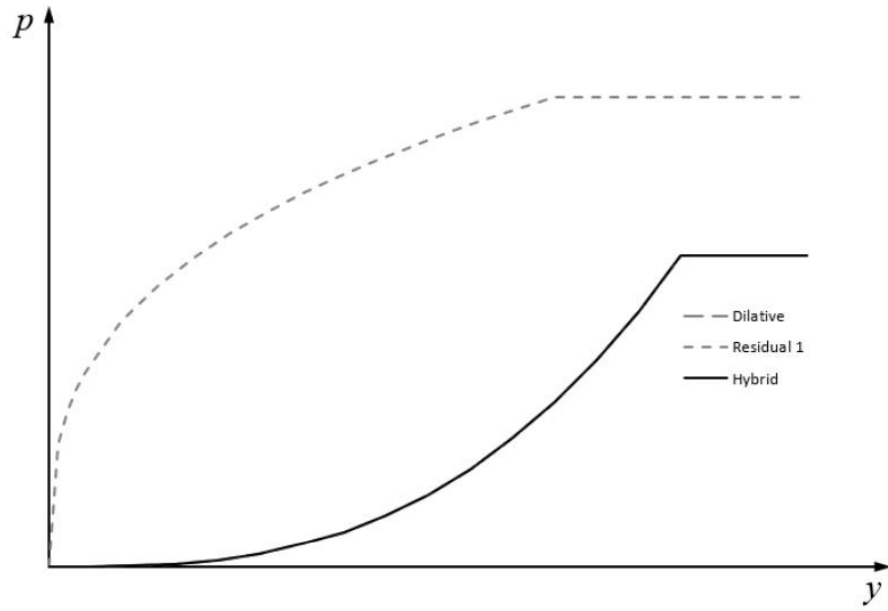

Figure 5.16: p-y curve for hybrid liquefied sand (case 1)

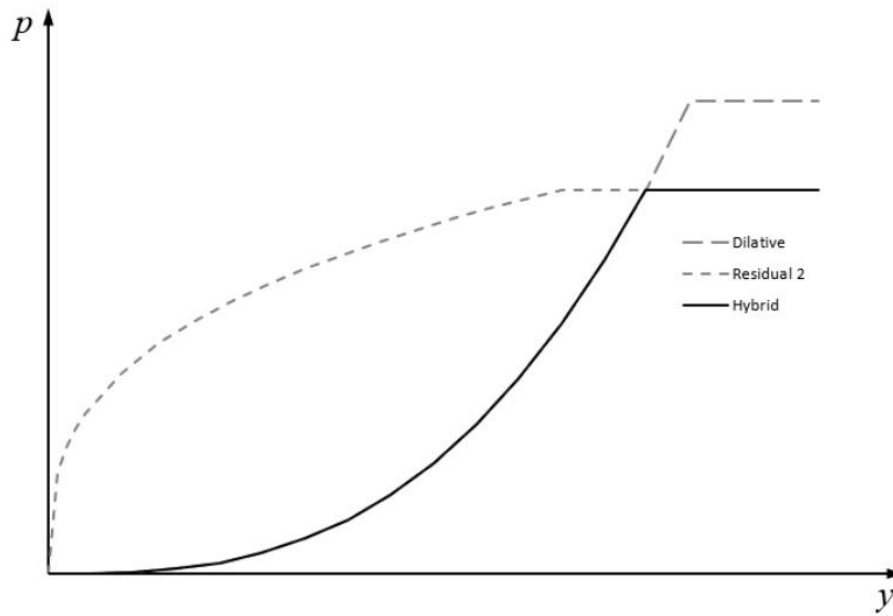

Figure 5.17: p-y curve for hybrid liquefied sand (case 2)

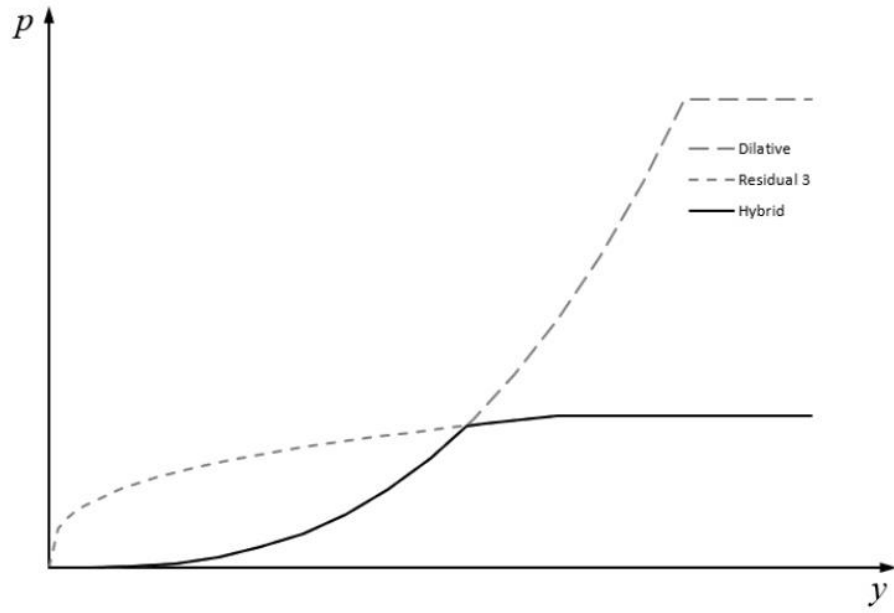

Figure 5.18: p-y curve for hybrid liquefied sand (case 3)

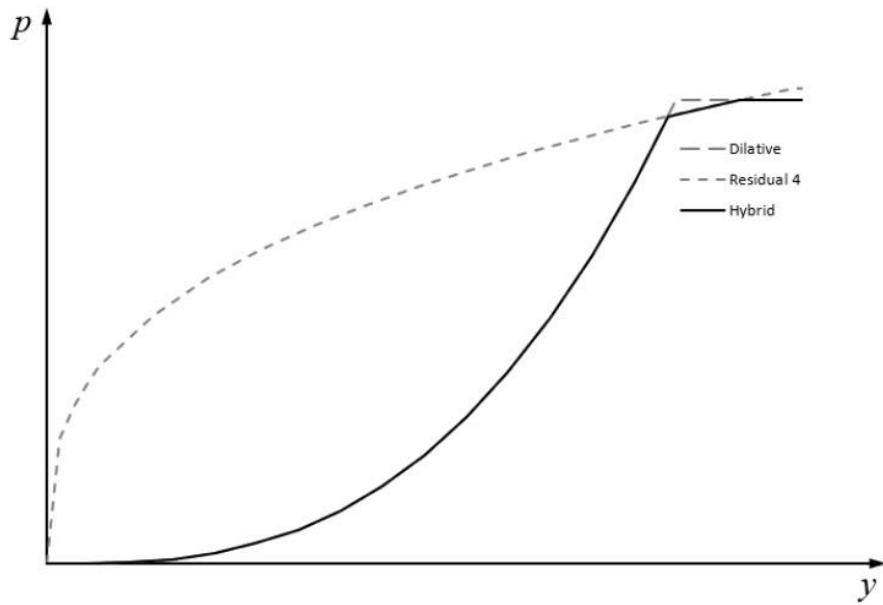

Figure 5.19: p-y curve for hybrid liquefied sand (case 4)

5.16. p-y curve for massive rock (Liang, Yang, and Nusairat, 2009)

Liang, Yang, and Nusairat (2009) developed a hyperbolic equation to describe p-y curves in rock. The development of the p-y curve for massive rock is presented in.

The general shape of the curve is defined by the following equation:

$$(58) \quad p = \frac{y}{\frac{1}{K_i} + \frac{y}{p_u}}$$

where K_i , the initial tangent slope of the p-y curve, is calculated as

$$(59) \quad K_i = E_m \left(\frac{D}{D_{ref}} \right) e^{-2v} \left(\frac{E_p I_p}{E_m D^4} \right)^{0.284}$$

and

- E_m = rock mass modulus
- D = diameter of the drilled shaft
- D_{ref} = reference shaft diameter equal to 0.3048 m or 12 inches
- $E_p I_p$ = bending stiffness of the drilled shaft

The ultimate resistance of the rock mass per unit shaft length, p_u , is the lesser of the resistances calculated near the ground surface and at great depth.

$$p_u = \min(p_{us}, p_{ud})$$

A passive wedge failure model is adopted for rock mass failure near the ground surface. p_{us} is calculated as:

$$(60) \quad p_{us} = 2C_1 \cos\theta \sin\beta + C_2 \sin\beta - 2C_4 \sin\theta - C_5$$

where

$$(61) \quad C_1 = H \tan\beta \sec\theta \left(c' + K_0 \sigma'_{v0} \tan\phi' + \frac{H}{2} K_0 \gamma' \tan\phi' \right)$$

$$(62) \quad C_2 = \frac{(D \tan\beta (\sigma'_{v0} + H\gamma') + H \tan^2 \beta \tan\theta (2\sigma'_{v0} + H\gamma') + c' (D + 2H \tan\beta \tan\theta) + 2C_1 \cos\beta \cos\theta)}{\sin\beta - \tan\phi' \cos\beta}$$

$$(63) \quad C_3 = C_2 \tan\phi' + c' (D \sec\beta + 2H \tan\beta \sec\beta \tan\theta)$$

$$(64) \quad C_4 = K_0 H \tan\beta \sec\theta \left(\sigma'_{v0} + \frac{1}{2} \gamma' H \right)$$

$$(65) \quad C_5 = \gamma' K_a (H - z_0) D \geq 0$$

$$(66) \quad K_a = \tan^2 \left(45 + \frac{\phi'}{2} \right)$$

$$(67) \quad K_0 = 1 - \sin \phi'$$

$$(68) \quad z_0 = \frac{2c'}{\gamma' \sqrt{K_a}} - \frac{\sigma'_{v0}}{\gamma'}$$

$$(69) \quad \beta = 45 + \phi' / 2$$

$$(70) \quad \theta = \phi' / 2$$

The ultimate resistance at great depth, p_{ud} , is calculated as:

$$(71) \quad p_{ud} = \left(\frac{\pi}{4} p_L + \frac{2}{3} \tau_{\max} - p_a \right) D$$

where

$$(72) \quad p_a = K_a \sigma'_v - 2c' \sqrt{K_a} \geq 0$$

$$(73) \quad p_L = \sigma'_v + \sigma_{ci} \left(m_b \left(\frac{\sigma'_v}{\sigma_{ci}} \right) + s \right)^a$$

$$(74) \quad \tau_{\max} = 14.23025 \sqrt{\sigma'_{ci}} \text{ for metric}$$

$$\tau_{\max} = 5.4194 \sqrt{\sigma'_{ci}} \text{ for imperial}$$

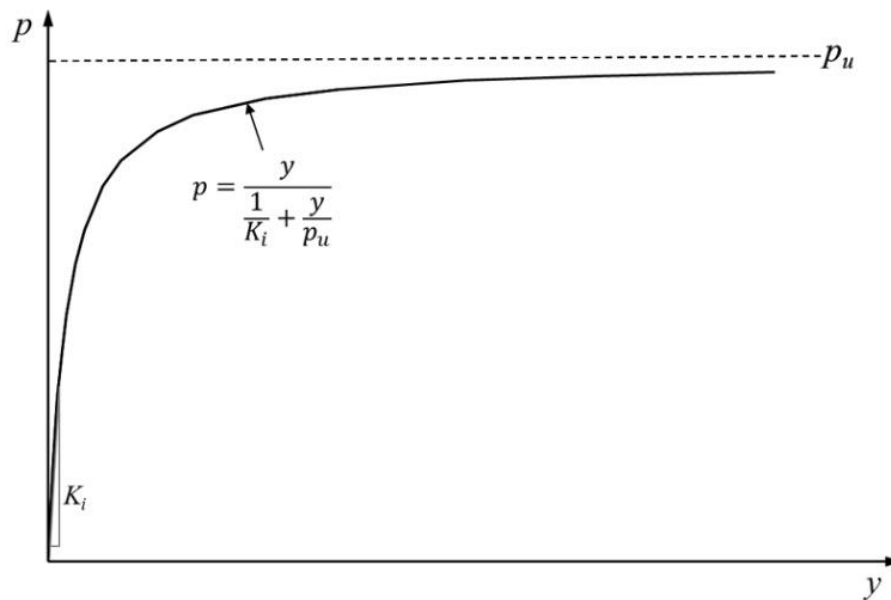

Figure 5.20: p-y curve for massive rock

6. Layered Soil Profile: Method of Georgiadis

The method of Georgiadis is based on the determination of the “equivalent depth” of every soil layer existing below the top layer. Since p-y curves are developed based on the depth into the soil, this is very important. To find the equivalent depth (z_2) of the layer existing below the top, the integrals of the ultimate soil resistance over depth are equated for the two layers with z_1 as the depth of the top layer. The values of p_{ult} are computed from the soil properties as noted above.

$$F_1 = \int_0^{z_1} p_{ult1} dz$$
$$F_1 = \int_0^{z_2} p_{ult2} dz$$

The p-y curves of the second layer are computed starting at z_2 (actual depth, z_1) moving down as you would until another layer is hit in terms of actual depth. This concept can be carried down for the rest of the existing layers the pile is in.

7. Ground Slope and Pile Batter

RSPile allows the input of a ground slope and a pile batter angle. In order to incorporate this into the analysis, the effective slope (θ) is calculated from the difference between the pile batter angle and the ground slope. Sign convention is clockwise positive for both values as shown in the "Sign Convention" document in the Help menu. This effective slope alters the calculation of the soil resistance for both clay and sand.

If there is an effective slope in **clay**, the ultimate soil resistance in front of the pile is,

$$p_{ult} = \left[3 + \frac{\gamma'}{c_u} z + \frac{J}{b} z \right] c_u b \frac{1}{1 + \tan \theta}$$

The ultimate soil resistance at the back of the pile is,

$$p_{ult} = \left[3 + \frac{\gamma'}{c_u} z + \frac{J}{b} z \right] c_u b \frac{\cos \theta}{\sqrt{2} \cos(45 + \theta)}$$

Notice the equations are the exact same as Equation 9 for soft clay with additional terms on the end. The same end terms can be applied to Equation 11 for submerged stiff clay and Equation 13 for dry stiff clay. The depth independent equations for ultimate resistance (Equations 10, 12, and 14) remain the same and the smaller of the values is still used.

Note: if the effective slope is equal to 0, these equations go back to their original form.

If there is an effective slope in **sand**, the ultimate soil resistance if the pile is deflecting down the slope is,

$$p_{sa} = \gamma H \left[\frac{K_0 H \tan \phi \sin \beta}{\tan(\beta - \phi) \cos \alpha} (4D_1^3 - 3D_1^2 + 1) + \frac{\tan \beta}{\tan(\beta - \phi)} (bD_2 + H \tan \beta \tan \alpha D_2^2) + K_0 H \tan \beta (\tan \phi \sin \beta - \tan \alpha) (4D_1^3 - 3D_1^2 + 1) - K_a b \right]$$

The ultimate soil resistance if the pile is deflecting up the slope is,

$$p_{sa} = \gamma H \left[\frac{K_0 H \tan \phi \sin \beta}{\tan(\beta - \phi) \cos \alpha} (4D_3^3 - 3D_3^2 + 1) + \frac{\tan \beta}{\tan(\beta - \phi)} (bD_4 + H \tan \beta \tan \alpha D_4^2) + K_0 H \tan \beta (\tan \phi \sin \beta - \tan \alpha) (4D_3^3 - 3D_3^2 + 1) - K_a b \right]$$

Where,

H = depth below ground surface (m)

$$K_a = \cos \theta \frac{\cos \theta - \sqrt{\cos^2 \theta - \cos^2 \phi}}{\cos \theta + \sqrt{\cos^2 \theta - \cos^2 \phi}}$$

$$D_1 = \frac{\tan \beta \tan \theta}{\tan \beta \tan \theta + 1},$$

$$D_2 = 1 - D_1,$$

$$D_3 = \frac{\tan \beta \tan \theta}{1 - \tan \beta \tan \theta},$$

$$D_4 = 1 + D_3$$

These equations for ultimate soil resistance in sand replace Equation 15 when there is an effective slope. Equation 16 remains the same and the smaller of the two values is still used. When modelling piles that are in a slope and/or battered, the user either has the option to use the method above by entering ground slope and batter angle, or more commonly, they can choose appropriate p-multipliers to alter the p-y curves. Suggested values are provided in Figure 7.1, however on important projects, a responsible engineer may wish to request full scale testing.

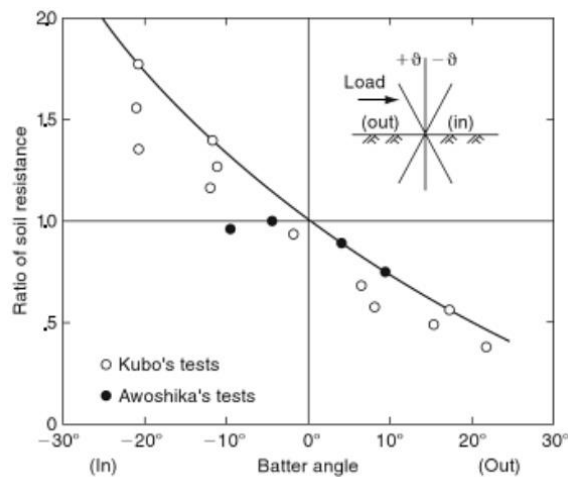

Figure 7.1: Proposed factor for modifying p-y curves for battered piles (Reese & Van Impe, 2011)

8. References

1. American Petroleum Institute. (2010). Recommended Practice for Planning, Designing, and Constructing Fixed Offshore Platforms - Working Stress Design, API RP 2A-WSD, 21st Edition, Errata and Supplement, 2010.
2. Franke, K.W., and Rollins, K.M. (2013). Simplified Hybrid p-y Spring Model for Liquefied Soils. *Journal of Geotechnical and Geoenvironmental Engineering*, ASCE, Vol. 139, No. 4, pp. 564-576.
3. Georgiadis, M. (1983). Development of p-y curves for layered soils. *Proceedings of the Geotechnical Practice in Offshore Engineering*, ASCE: 536-545.
4. Isenhower, W.M. (1999). Analysis of pile groups subjected to deep-seated soil displacements. *Analysis, Design, Construction, and Testing of Deep Foundations*, Austin, Texas, (OTRC): 150164.
5. Johnson, R. M., Parsons, R. L., Dapp, S. D., and Brown, D. A. (2006). "Soil Characterization and p-y Curve Development for Loess," Kansas Department of Transportation, Bureau of Materials and Research, July.
6. Liang, R. Yang, K., and Nusairat.J. (2009). "p-y Criterion for Rock Mass." *Journal of Geotechnical and Geoenvironmental Engineering*. Vol. 135, No. 1, pp. 26-36.
7. Matlock, H. (1970). Correlations for design of laterally loaded piles in soft clay. *Proceedings of the II Annual Offshore Technology Conference, Houston, Texas*, (OTC 1204): 577-594.
8. Peck, R.B., W.E. Hanson & T.H. Thorburn. (1974). *Foundation engineering*, 2nd edn. New York: Wiley.
9. Reese, L.C., W.R. Cox & F.D. Koop. (1974). Field testing and analysis of laterally loaded piles in sand. *Proceedings of the VI Annual Offshore Technology Conference, Houston, Texas*, 2(OTC 2080): 473-485.
10. Reese, L.C. & K.J. Nyman. (1978). Field load test of instrumented drilled shafts at Islamorada, Florida. A report to Girdler Foundation and Exploration Corporation (unpublished), Clearwater, Florida.
11. Reese, L.C. & W.F. Van Impe. (2011). *Single Piles and Pile Groups Under Lateral Loading*, 2nd Edition. London: Taylor & Francis Group.
12. Reese, L.C., W.R. Cox & F.D. Koop. (1975). Field testing and analysis of laterally loaded piles in stiff clay. *Proceedings of the VII Annual Offshore Technology Conference, Houston, Texas*, 2(OTC 2312): 672-690.
13. Rollins, K.M., Gerber, T.M., Lane, J.D., Ashford, S.A. (2005a). Lateral Resistance of a Full-Scale Pile Group in Liquefied Sand. *Journal of the Geotechnical and Geoenvironmental Engineering Division*, ASCE. Vol. 131, pp 115-125.
14. Simpson, M. and Brown, D.A. (2003). Development of P-Y Curves for Piedmont Residual Soils. Project No. B-424 (2). Highway Research Center, Harbert Engineering Center, Auburn University.
15. Wang, S.T., and Reese, L.C. (1998). Design of Piles Foundations in Liquefied Soils. *Geotechnical and Earthquake Engineering and Soil Dynamics III*, Geotechnical Special Publication No. 75, ASCE, pp. 1331-1343.
16. Welch, R.C. & L.C. Reese. (1972). Laterally loaded behavior of drilled shafts. *Research Report 35-65-89*. Center for Highway Research. University of Texas, Austin.