

RocTunnel3

Kinematics Computations

Verification Manual

Table of Contents

Introduction	4
1. RocTunnel3 Verification Problem #1: Blocks Results – No External Forces Applied.....	5
1.1. Problem Description	5
1.2. Geometry and Material Properties	5
1.3. Results.....	7
2. RocTunnel3 Verification Problem #2: Uniform Joint Water Pressure	8
2.1. Problem Description	8
2.2. Geometry and Material Properties	8
2.3. Results.....	8
3. RocTunnel3 Verification Problem #3: Shotcrete Support	10
3.1. Problem Description	10
3.2. Geometry and Material Properties	10
3.3. Results.....	11
4. RocTunnel3 Verification Problem #4: Seismic Loading	13
4.1. Problem Description	13
4.2. Geometry and Material Properties	13
4.3. Analytical solution.....	14
4.4. Results.....	15
5. RocTunnel3 Verification Problem #5: Support Pressure.....	17
5.1. Problem Description	17
5.2. Geometry and Material Properties	17
5.3. Results.....	19
6. RocTunnel3 Verification Problem #6: Ru Water Pressure.....	21
6.1. Problem Description	21
6.2. Geometry and Material Properties	21
6.3. Analytical solution.....	22
6.4. Results.....	23
7. RocTunnel3 Verification Problem #7: Loading	24
7.1. Problem Description	24
7.2. Geometry and Material Properties	24
7.2.1. Point Load.....	24

7.2.2. Line Load	25
7.2.3. Surface Load	26
7.3. Analytical solution.....	27
7.4. Results.....	29
8. RocTunnel3 Verification Problem #8: Groundwater – Piezometric Surface	30
8.1. Problem Description	30
8.2. Geometry and Material Properties	30
8.3. Results.....	31
9. RocTunnel3 Verification Problem #9: Groundwater – Water Pressure Grid	33
9.1. Problem Description	33
9.2. Geometry and Material Properties	33
9.3. Results.....	36
10.RocTunnel3 Verification Problem #10: Bolts	38
10.1. Problem Description	38
10.2. Geometry and Material Properties	38
10.3. Problem Description	40
10.4. Results.....	42
11.RocTunnel3 Verification Problem #11: Successive Failure Verification Problem	44
11.1. Problem Description	44
11.2. Geometry and Material Properties	44
11.3. Results.....	44
12.References	46

Introduction

This document presents examples used to verify the validity of kinematics computations by the Kinematic Engine in RocTunnel3. Two different types of comparisons are used to accomplish this:

UnWedge vs. RocTunnel3 Results

In this case, the model is first created in UnWedge and then imported into RocTunnel3. Consistent results are expected between the two software programs since they analyze the same model geometry and properties with both Limit Equilibrium Method (LEM) engines based on Goodman and Shi's "Block Theory" (1985).

It is also worth noting that when importing the model from UnWedge into RocTunnel3, joints can be imported as either Measured Joints or Joint Surfaces. In both cases, users will arrive at the same model. For consistency, joints are imported as Measured Joints in the verification problems.

RocTunnel3 vs. Analytical Results

In this case, the model is created in RocTunnel3. Hand calculations are performed to obtain expected results and compare them with RocTunnel3's results.

1. RocTunnel3 Verification Problem #1: Blocks Results – No External Forces Applied

Geometry Verification Problem [RocTunnel3 1.001 & UnWedge 5.019]

1.1. Problem Description

This verification problem compares kinematic results between UnWedge and RocTunnel3 using equivalent model geometry with no external forces (e.g., not groundwater, loading, or supports) applied. The only forces considered in the computation of the Factor of Safety are the weight of the block which acts as a driving force, and shear force along contact joints (if any) which acts as a resisting force. Only one stage is defined in RocTunnel3 for this comparison.

The model consists of a simple 10 m x 10 m extruded tunnel section with four tetrahedral wedges, each formed by the intersection of three joint planes.

NOTE: This example is also used as a base model to verify staging in later examples. The results of this analysis serve as a baseline for when no external forces are acting on the block.

1.2. Geometry and Material Properties

The model input geometry and properties data are presented in Table 1.2.1, Table 1.2.2, Table 1.2.3, and Table 1.2.4.

Table 1.2.1: General Data

Tunnel Trend (°)	Tunnel Plunge (°)	Rock Unit Weight (MN/m ³)
0	0	0.027

Table 1.2.2: Joint Orientations

Joint	Dip (°)	Dip Direction (°)
1	45	90
2	45	330
3	45	210

Table 1.2.3: Joint Properties

Shear Strength Model	Phi (°)	Cohesion (MPa)	Tensile Strength (MPa)
Mohr-Coulomb	35	0.1	0

All three joints have the same joint properties.

Table 1.2.4: Tunnel Opening Section Coordinates

Vertex	X (m)	Y (m)
1	0	0
2	0	10
3	10	10
4	10	0

The resulting blocks from UnWedge and RocTunnel3 are shown in Figure 1.1 and Figure 1.2, respectively.

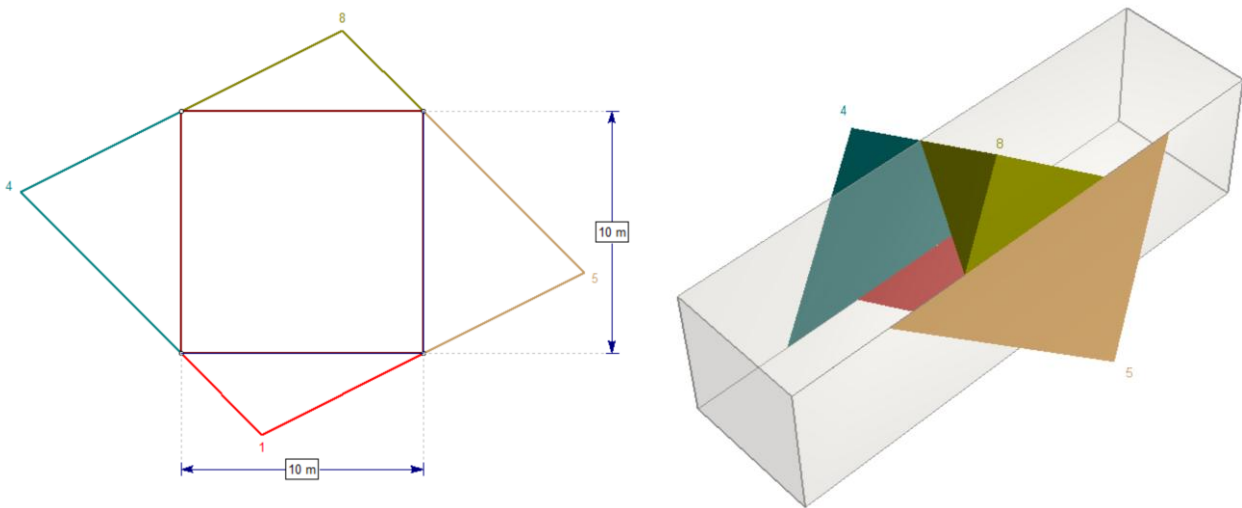

Figure 1.1: Tunnel and Blocks Geometry in UnWedge

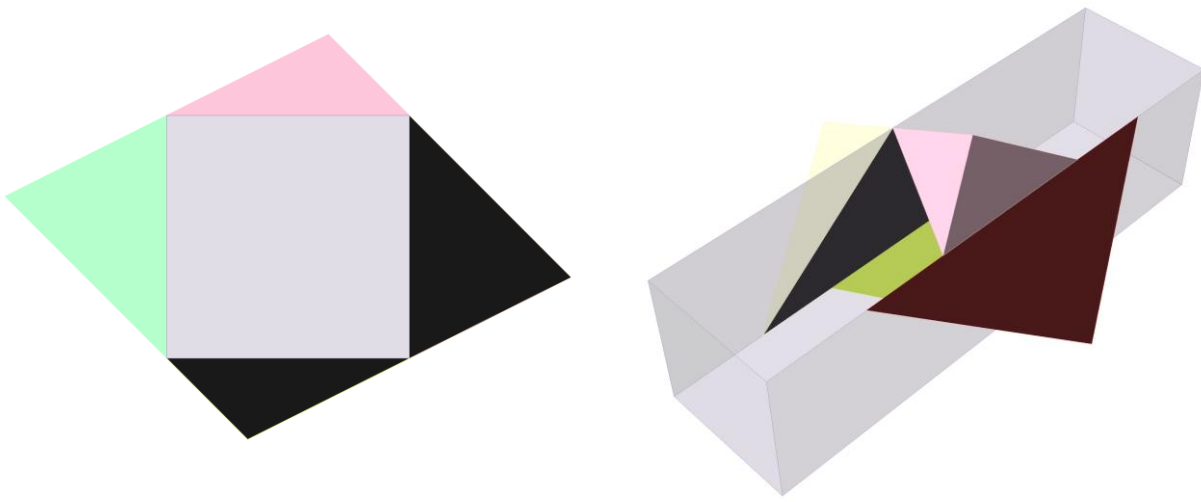

Figure 1.2: Tunnel and Blocks Geometry in RocTunnel3 (from Import UnWedge File)

1.3. Results

Four blocks are formed. The Factor of Safety (FS) values of the blocks computed with RocTunnel3 show an exact agreement with FS calculations in UnWedge as presented in Table 1.3.1.

Table 1.3.1: Factor of Safety Results Compared to UnWedge

Block	RocTunnel3 FS	UnWedge FS
[1] Floor Wedge	Stable	Stable
[4] Lower Left Wedge	2.922	2.922
[5] Upper Right Wedge	5.285	5.285
[8] Roof Wedge	0	0

Driving and Resisting Force values for each block in this example are presented in Table 1.3.2. This is used for comparison in later examples when no external force is applied in certain stages.

Table 1.3.2: Driving and Resisting Forces Results (when No External Forces Applied)

Block	Driving Force (MN)	Resisting Force (MN)	Weight (MN)
[1] Floor Wedge	0	0	1.732
[4] Lower Left Wedge	4.899	14.317	6.928
[5] Upper Right Wedge	3.098	16.375	6.928
[8] Roof Wedge	1.732	0	1.732

2. RocTunnel3 Verification Problem #2: Uniform Joint Water Pressure

Joint Water Pressure Verification Problem [RocTunnel3 1.001 & UnWedge 5.019]

2.1. Problem Description

This example compares kinematic computations between UnWedge and RocTunnel3 using equivalent model geometry with constant water pressure applied on all joints. Only one stage is defined in RocTunnel3 for this comparison.

2.2. Geometry and Material Properties

The geometry used in this verification problem is identical to that of Verification Problem #1. For detailed geometry, refer to Geometry and Material Properties in Verification Problem #1. Constant Joint Water Pressure of 0.025 MPa is applied to all the joints. Table 2.2.1 outlines the Joint Property data for this model.

Table 2.2.1: Joint Properties

Shear Strength Type	Phi (°)	Cohesion (MPa)	Tensile Strength (MPa)	Water Pressure Method	Water Pressure (MPa)
Mohr-Coulomb	35	0.1	0	Uniform/Constant	0.025

The resulting geometries for UnWedge and RocTunnel3 in this model are identical to Figure 1.1 and Figure 1.2, respectively in Verification Problem #1.

2.3. Results

Four blocks are formed. The Factor of Safety (FS) of blocks computed with RocTunnel3 agree with FS calculations in UnWedge. The results are presented in Table 2.3.1.

Table 2.3.1: Factor of Safety Results Compared to UnWedge

Block	RocTunnel3 FS	UnWedge FS
[1] Floor Wedge	Stable	Stable
[4] Lower Left Wedge	1.857	1.857
[5] Upper Right Wedge	2.681	2.681
[8] Roof Wedge	0	0

3. RocTunnel3 Verification Problem #3: Shotcrete Support

Support Verification Problem [RocTunnel3 1.001 & UnWedge 5.019]

3.1. Problem Description

This verification problem compares kinematic computations between UnWedge and RocTunnel3 using equivalent model geometry, with a uniform Shotcrete layer applied around the entire tunnel perimeter. There are three stages in this RocTunnel3 model, and Shotcrete is only applied in Stage 2.

3.2. Geometry and Material Properties

The geometry is identical to that of Verification Problem #1. For detailed geometry, refer to Geometry and Material Properties in Verification Problem #1. Shotcrete is applied around the perimeter of the tunnel. The Shotcrete properties are listed in Table 3.2.1.

Table 3.2.1: Shotcrete Properties

Shear Strength (MPa)	Unit Weight (MN/m ²)	Thickness (m)	Install in Stage	Remove in Stage
1	0.026	0.1	Stage 2	Stage 3

The resulting blocks from UnWedge and RocTunnel3 are shown in Figure 3.1 and

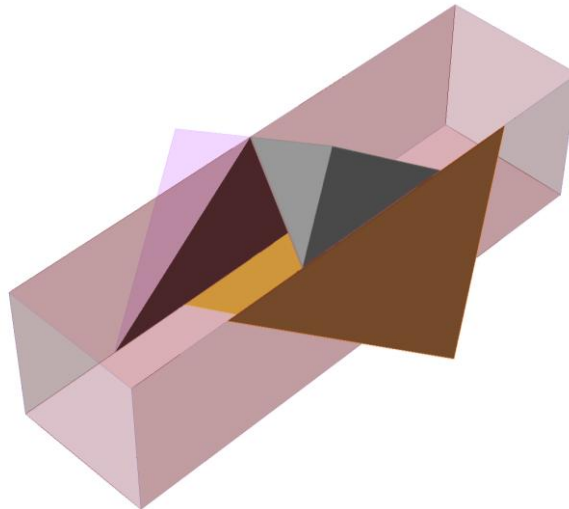

Figure 3.2, respectively.

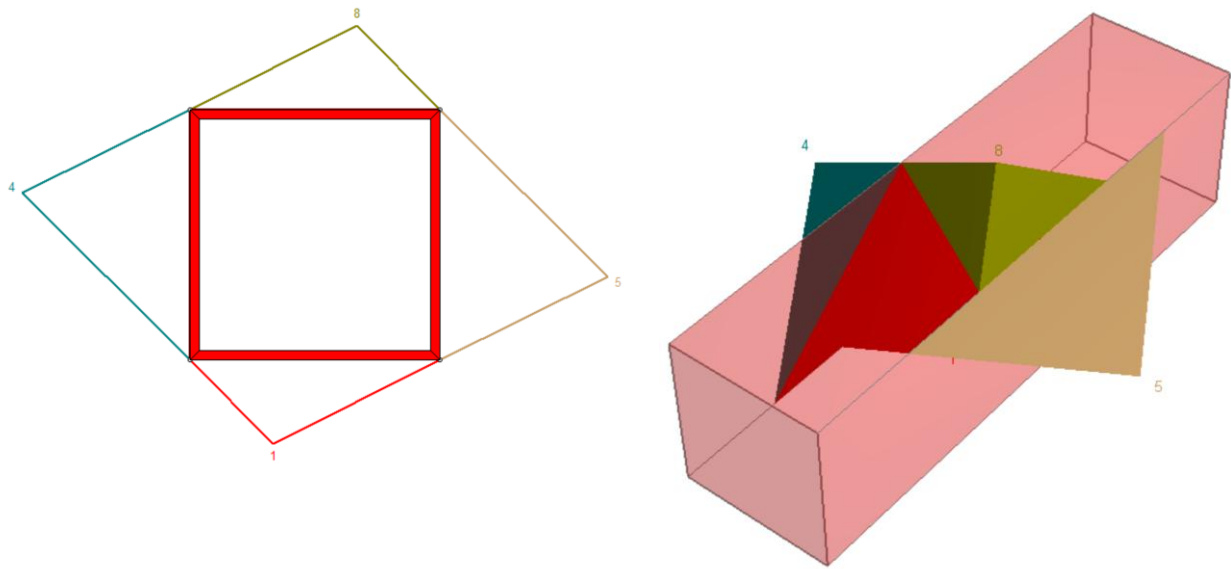

Figure 3.1: Tunnel and Block Geometry in UnWedge with Shotcrete Applied

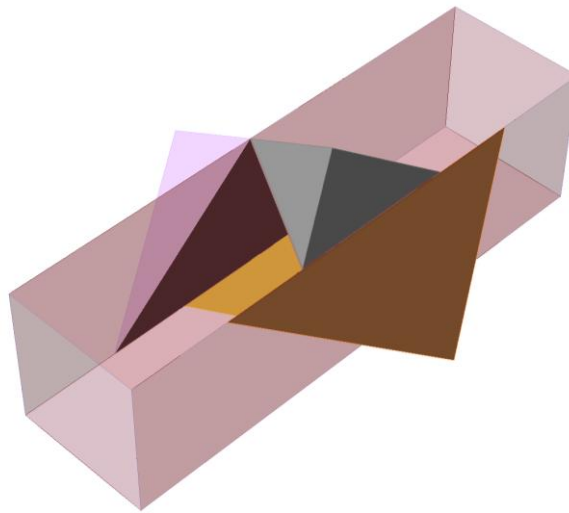

Figure 3.2: Tunnel and Block Geometry in RocTunnel3 with Shotcrete Applied in Stage 2

The Factor of Safety (FS), Driving Force, and Resisting Force values in Stages 1 and 3 should be identical to those in Verification Problem #1 with no Shotcrete applied (Table 1.3.1 and Table 1.3.2) and Stage 2 should match UnWedge with Shotcrete applied.

3.3. Results

Four blocks are formed. First, the FS values in Stage 1 and Stage 3 in RocTunnel3 are compared with the FS values in Verification Example #1 in Table 3.3.1. The values agree when no Shotcrete is applied.

Table 3.3.1: Stage 1 and Stage 3 Factor of Safety Compared to Verification Problem #1

Block	RocTunnel3 Stage 1 FS	RocTunnel3 Stage 3 FS	Verification Problem #1 FS
[1] Floor Wedge	Stable	Stable	Stable
[4] Lower Left Wedge	2.922	2.922	2.922
[5] Upper Right Wedge	5.285	5.285	5.285
[8] Roof Wedge	0	0	0

Next, the Factor of Safety of the blocks in Stage 2 in RocTunnel3 is compared with the UnWedge results in Table 3.3.2. Exact agreement in computations is observed.

Table 3.3.2: Stage Factor of Safety Compared to UnWedge

Block	RocTunnel3 Stage 2 FS	UnWedge FS
[1] Floor Wedge	Stable	Stable
[4] Lower Left Wedge	4.092	4.092
[5] Upper Right Wedge	7.281	7.281
[8] Roof Wedge	1.84	1.84

This verifies that both Shotcrete forces and the application of staging are computed as expected.

4. RocTunnel3 Verification Problem #4: Seismic Loading

Seismic Loading Verification Problem [RocTunnel3 1.001]

4.1. Problem Description

This example analyzes block results with Seismic Loading applied in RocTunnel3. There are three stages in this RocTunnel3 model. Seismic Loading is applied in Stage 2 and Stage 3. In Stage 3, a Stage Factor of 0.5 is applied, which reduces the Seismic force by half. The results are verified with analytical calculations.

4.2. Geometry and Material Properties

The tunnel geometry is identical to that of Verification Problem #1. For detailed tunnel geometry, refer to Geometry and Material Properties in Verification Problem #1. Measured Joints data is modified to only form the Roof and Upper Right Wedge.

The Seismic Loading data is presented in Table 4.2.1.

Table 4.2.1: Seismic Loading

Orientation	Seismic Coefficient	Apply in Stage	Apply Stage Factor	Stage 3 Stage Factor
Sliding Direction	0.3	Stage 2	Yes	0.5

The modified Measured Joints data is presented in Table 4.2.2.

Table 4.2.2: Measured Joints Data

Dip (°)	Dip Direction (°)	X (m)	Y (m)	Z (m)	Radius (m)
45	330	12.222222	-3.849002	4.4444444	9.7499604
45	210	12.222222	3.8490018	4.4444444	9.7499604
45	90	12.222222	0	7.7777778	11.967033
45	330	5.5555556	1.9245009	11.111111	5.9835165
45	90	8.8888889	3.257E-15	11.111111	5.9835165
45	210	5.5555556	-1.924501	11.111111	5.9835165

The resulting geometry in RocTunnel3 is shown in Figure 4.1.

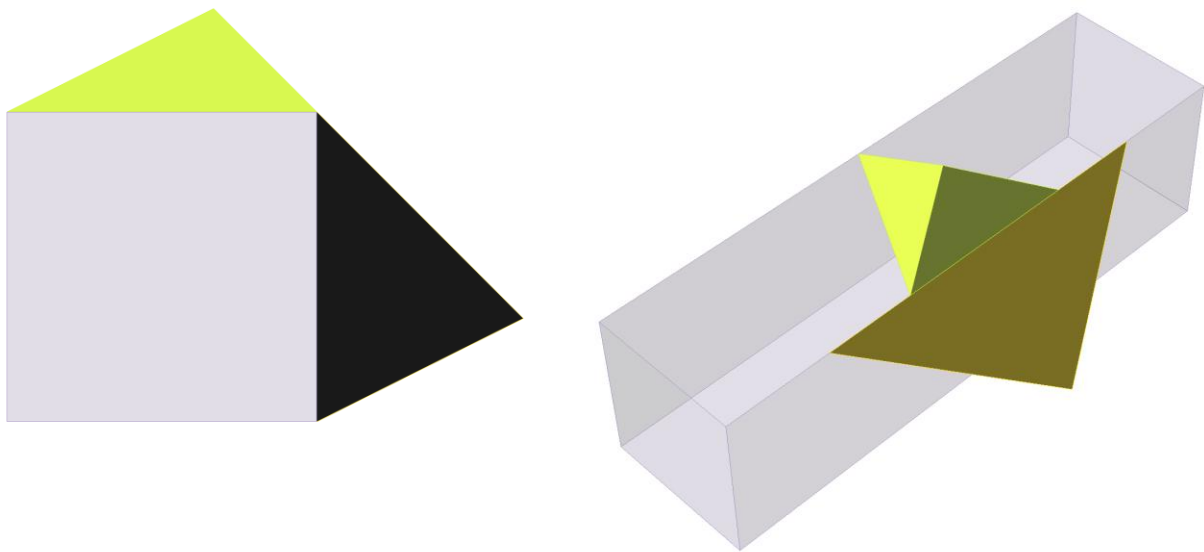

Figure 4.1: Tunnel and Block Geometry in RocTunnel3

Driving Force and Resisting Force values in Stage 1 should be the same as in Verification Problem #1 (no Seismic Loading applied). Stage 2 results should account for the applied Seismic Loading, and Stage 3 results should account for the applied Seismic Loading factored by the Seismic Coefficient Factor.

4.3. Analytical solution

This section presents the calculation of resultant Driving Force for each block, in each stage. Only Driving Force calculations are demonstrated since the Seismic Load is applied in the Sliding Direction and Resisting Force remains constant.

Since the Seismic Force is in the Sliding Direction, the calculation of seismic force vector is computed as follows:

$$\text{seismic force} = \text{block weight} \times \text{seismic coefficient} \quad (4.1)$$

Stage 1

Since no Seismic Load is applied in Stage 1, the Driving Force for the Roof Wedge and Upper Right Wedge (Table 4.3.1) should be equal to their respective values in Table 1.3.2 in Verification Problem #1.

Table 4.3.1: Stage 1 Driving and Resisting Forces with No Seismic Loading Applied

Block	Driving Force (MN)	Resisting Force (MN)	Weight (MN)
[5] Upper Right Wedge	3.098	16.375	6.928
[8] Roof Wedge	1.732	0	1.732

Stage 2

In Stage 2, Seismic Loading is applied in the Sliding Direction with a Coefficient of 0.3. The Weight for each block can be obtained from Table 4.3.1.

Roof Wedge:

$$seismic\ force = weight \times seismic\ coefficient = (1.732\ MN)(0.3) = 0.520\ MN$$

$$driving\ force = driving\ force_{Stage\ 1} + seismic\ force = 1.732\ MN + 0.52\ MN = 2.252\ MN$$

Upper Right Wedge:

$$seismic\ force = weight \times seismic\ coefficient = (6.928\ MN)(0.3) = 2.078\ MN$$

$$driving\ force = driving\ force_{Stage\ 1} + seismic\ force = 3.098\ MN + 2.078\ MN = 5.176\ MN$$

Stage 3

In Stage 3, Seismic Loading is applied in the Sliding Direction with a Coefficient of 0.3, and a Stage Factor of 0.5 is also applied.

Roof Wedge:

$$seismic\ force = weight \times seismic\ coefficient \times stage\ factor = (1.732\ MN)(0.3)(0.5) = 0.26\ MN$$

$$driving\ force = driving\ force_{Stage\ 1} + seismic\ force = 1.732\ MN + 0.26\ MN = 1.992\ MN$$

Upper Right Wedge:

$$seismic\ force = weight \times seismic\ coefficient \times stage\ factor = (6.928\ MN)(0.3)(0.5) = 1.04\ MN$$

$$driving\ force = driving\ force_{Stage\ 1} + seismic\ force = 3.098\ MN + 1.04\ MN = 4.138\ MN$$

4.4. Results

Analytical solution results are in exact agreement between RocTunnel3 and hand calculations across all three stages. These forces are summarized in Table 4.4.1.

Table 4.4.1: Stage 1 Driving and Resisting Force Compared to Analytical Solution

Force Type	Stage	[5] Upper Right Wedge		[8] Roof Wedge	
		RocTunnel3 (MN)	Analytical (MN)	RocTunnel3 (MN)	Analytical (MN)
Driving Force	1	3.098	3.098	1.732	1.732
	2	5.177	5.176	2.252	2.252
	3	4.138	4.138	1.992	1.992
Resisting Force	1	16.375	16.375	0	0
	2	16.375	16.375	0	0
	3	16.375	16.375	0	0

This verifies Seismic Loading, its staging and stage factors.

5. RocTunnel3 Verification Problem #5: Support Pressure

Support Verification Problem [RocTunnel3 1.001 & UnWedge 5.019]

5.1. Problem Description

This example compares kinematic computations between UnWedge and RocTunnel3 using equivalent model geometry with Active and Passive Support Pressure around the entire tunnel perimeter. There are three stages in this RocTunnel3 model. Support Pressure is applied in Stage 2 and Stage 3. In Stage 3, a Stage Factor of 0.5 is also applied.

Two UnWedge models with the same geometries and properties are created with the only difference being Active or Passive application of Support Pressure.

5.2. Geometry and Material Properties

The geometry is identical to that of Verification Problem #1. For detailed geometry, refer to Geometry and Material Properties in Verification Problem #1. Active/Passive Support Pressure is applied around the perimeter of the tunnel.

The Support Pressure data is presented in Table 5.2.1.

Table 5.2.1: Support Pressure

	Pressure (MPa)	Orientation	Force Application	Install in Stage	Remove in Stage	Apply Stage Factor	Stage 3 Magnitude Factor
Case 1: Active Support Pressure	0.01	Normal	Active	Stage 2	Never	Yes	0.5
Case 2: Passive Support Pressure	0.01	Normal	Passive	Stage 2	Never	Yes	0.5

The resulting geometries in UnWedge and RocTunnel3 are shown in Figure 5.1 and Figure 5.2, respectively.

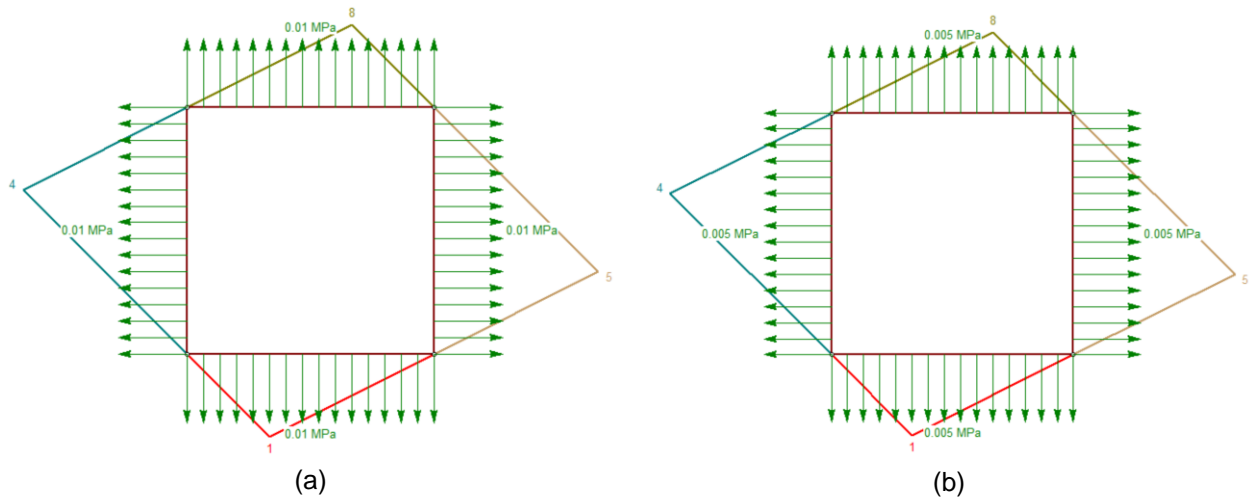

Figure 5.1: Support Pressure in UnWedge (a) 0.01 MPa (b) 0.005 MPa

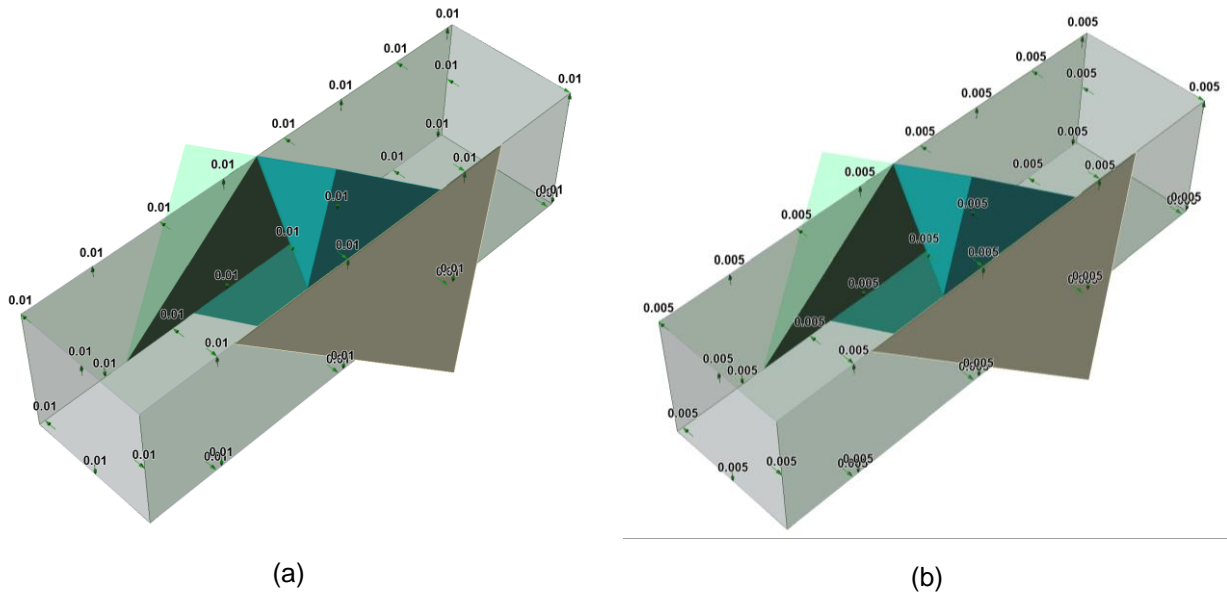

Figure 5.2: Support Pressure in RocTunnel3 (a) 0.01 MPa in Stage 2 (b) 0.005 MPa in Stage 3

Stage 1

The FS values in Stage 1 are expected to be the same as values in Verification Problem #1 (no Support Pressure applied, Table 1.3.1).

Stage 2

Stage 2 results should account for Support Pressure and match values in UnWedge.

Stage 3

Stage 3 results should account for Support Pressure and Stage Factor (a factor applied to the magnitude). The factored Support Pressure is equivalent to specifying a Support Pressure Magnitude of 0.005 MPa.

$$\text{support pressure magnitude} = \text{magnitude} \times \text{magnitude factor} = (0.01 \text{ MPa})(0.5) = 0.005 \text{ MPa}$$

5.3. Results

RocTunnel3 results are compared to expected values in Table 5.3.1, Table 5.3.2, and Table 5.3.3. It is observed that the Analytical Solution results align closely with the software results across different stages.

Table 5.3.1: Stage 1 Factor of Safety Results without Passive Support Pressure Compared to Verification Problem #1

Block	RocTunnel3 Stage 1 FS	Verification Problem #1 FS
[1] Floor Wedge	Stable	Stable
[4] Lower Left Wedge	2.922	2.922
[5] Upper Right Wedge	5.285	5.285
[8] Roof Wedge	0	0

Table 5.3.2: Stage 2 Factor of Safety Results Compared to UnWedge

Block	RocTunnel3 Stage 2 FS (Active Support Pressure)	UnWedge FS (Active Support Pressure)	RocTunnel3 Stage 2 FS (Passive Support Pressure)	UnWedge FS (Passive Support Pressure)
[1] Floor Wedge	Stable	Stable	Stable	Stable
[4] Lower Left Wedge	3.644	3.647	3.206	3.206
[5] Upper Right Wedge	8.157	8.149	5.765	5.766
[8] Roof Wedge	0	0	0.333	0.333

Table 5.3.3: Stage 3 Factor of Safety Results Compared to UnWedge

Block	RocTunnel3 Stage 3 FS (Active Support Pressure)	UnWedge FS (Active Support Pressure)	RocTunnel3 Stage 3 FS (Passive Support Pressure)	UnWedge FS (Passive Support Pressure)
[1] Floor Wedge	Stable	Stable	Stable	Stable
[4] Lower Left Wedge	3.251	3.252	3.064	3.064
[5] Upper Right Wedge	6.433	6.431	5.525	5.526
[8] Roof Wedge	0	0	0.167	0.167

This verifies the computation of Support Pressure, its stage factors, and staging.

6. RocTunnel3 Verification Problem #6: Ru Water Pressure

Groundwater Verification Problem [RocTunnel3 1.001]

6.1. Problem Description

This example verifies the computations for Ru Water Pressure in RocTunnel3.

6.2. Geometry and Material Properties

The geology is comprised of two horizontal rock layers and a 10 m x 10 m x 10 m excavation located in the center of the rock mass. Input material properties and joint properties are listed in Table 6.2.1 and Table 6.2.2, respectively.

Table 6.2.1: Material Properties

Material	Unit Weight (MN/m ³)	Groundwater Method	Ru Value
Material 1 (Purple)	0.026	Ru Coefficient	0.8
Material 2 (Yellow)	0.03	Ru Coefficient	0.6
Excavation	N/A	N/A	N/A

Table 6.2.2: Joint Properties

Shear Strength Type	Phi (°)	Cohesion (MPa)	Tensile Strength (MPa)	Water Pressure Method
Mohr-Coulomb	35	0.1	0	Material Dependent

Five orthogonal Measured Joints are listed in Table 6.2.3 to form a 4 x 4 x 4 block on the roof of the excavation. All joints have the same joint properties as defined in Table 6.2.2.

Table 6.2.3: Measured Joints Definition

Joint	Dip (°)	Dip Direction (°)	X (m)	Y (m)	Z (m)	Radius (m)
1	90	90	13	15	20	5
2	90	90	17	15	20	5
3	90	0	15	13	20	5

4	90	0	15	17	20	5
5	0	0	15	15	24	5

There are two stages defined. Material assignment in each stage for each Rock is outlined in Table 6.2.4.

Table 6.2.4: Staged Materials

Geology	Start Elevation (m)	End Elevation (m)	Stage 1	Stage 2
Layer 1	28	30	Material 2	Material 1
Layer 2	0	28	Material 1	Material 2
Excavation	10	20	No Material	No Material

Figure 6.1 shows the RocTunnel3 model for Stage 1 and Stage 2. In this example, to simplify calculations, the focus is on one joint plane only; Joint 5 in Table 6.2.3. It is parallel to the upper surface of the tunnel. Ru Water Pressure is expected to be consistent across the entire plane since the surface is horizontal.

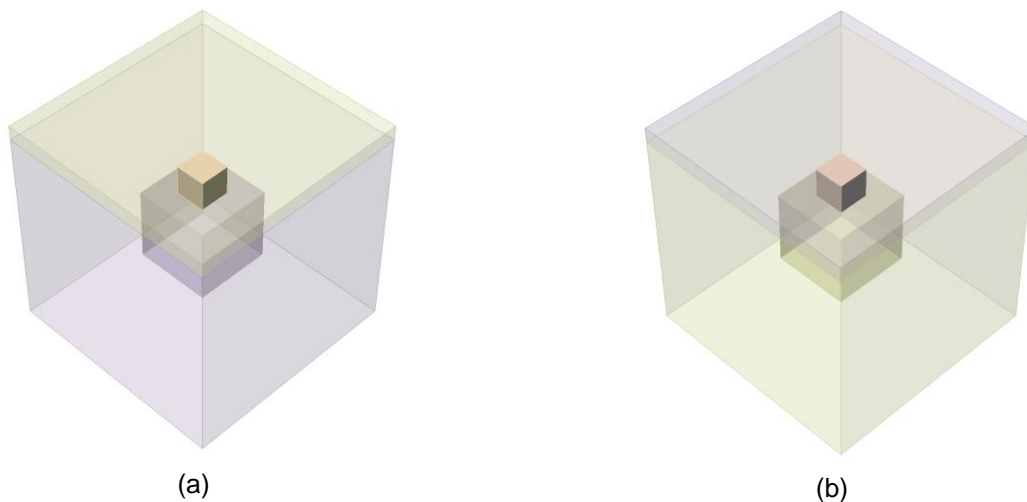

Figure 6.1: Ru Water Pressure in RocTunnel3 (a) Stage 1 (b) Stage 2

6.3. Analytical solution

Here, hand calculations are performed to verify our results. The depth of Layer 1 in the z direction is 2 m, and the depth of Layer 2 up to Joint 5 is 4 m for both Stage 1 and Stage 2. The Ru Water Pressure magnitude is computed as the sum of vertical earth pressure multiplied by the Ru Coefficient and acts normal to the joint surface.

$$ru\ water\ pressure = \sum_i(rock\ thickness_i \times rock\ unit\ weight_i \times ru\ coefficient_i) \quad (6.1)$$

Stage 1

The Ru Water Pressure acting on Joint 5 is computed as:

$$ru\ water\ pressure = (2\ m) \left(0.03 \frac{MN}{m^3} \right) (0.6) + (4\ m) \left(0.026 \frac{MN}{m^3} \right) (0.8) = 0.1192\ MPa$$

Stage 2

$$ru\ water\ pressure = (1\ m) \left(0.026 \frac{MN}{m^3} \right) (0.8) + (4\ m) \left(0.03 \frac{MN}{m^3} \right) (0.6) = 0.1136\ MPa$$

6.4. Results

It is observed that the Analytical Solution Results align exactly with the RocTunnel3 Results across both stages. This verifies the functioning of Ru Water Pressure and its staging.

Table 6.4.1: Joint 5 Water Pressure Results Compared to Analytical Ru Water Pressure

Stage	RocTunnel3 (MPa)	Analytical (MPa)
1	0.1192	0.1192
2	0.1136	0.1136

7. RocTunnel3 Verification Problem #7: Loading

Loading Verification Problem [RocTunnel3 1.001]

7.1. Problem Description

This example verifies the computations for Line and Surface load. There are two separate models for each load type. The geometries are the same for each model; the only difference is the type of load applied.

7.2. Geometry and Material Properties

The tunnel geometry, material properties, and joint properties are identical to that of Verification Problem #1. For detailed geometry, refer to Geometry and Material Properties in Verification Problem #1. Loading is applied to the block.

The Measured Joint data is modified with four orthogonal Measured Joints as listed in Table 7.2.1 to form a block on the roof of the excavation. All joints have the same joint properties as defined in Table 6.2.2

Table 7.2.1: Modified Measured Joints Orientations

Joint	Dip (°)	Dip Direction (°)	X (m)	Y (m)	Z (m)	Radius (m)
1	50	270	10	0	2	13
2	0	0	10	0	8	13
3	90	0	10	-5	2	13
4	90	0	10	5	2	13

7.2.1. Point Load

The orientation of the Point Load is applied in the unloaded block's sliding direction and properties are listed in Table 7.2.2.

Table 7.2.2: Point Load

Trend (°)	Plunge (°)	Magnitude (MN)	Install in Stage	Remove at Stage	Apply Stage Factor	Stage 3 Magnitude Factor
270	50	1	Stage 2	Never	Yes	0.5

Figure 7.1 shows the resulting geometry with a 1 MN point load applied in Stage 2 and 0.5 MN point load applied in Stage 3 (factored by 0.5).

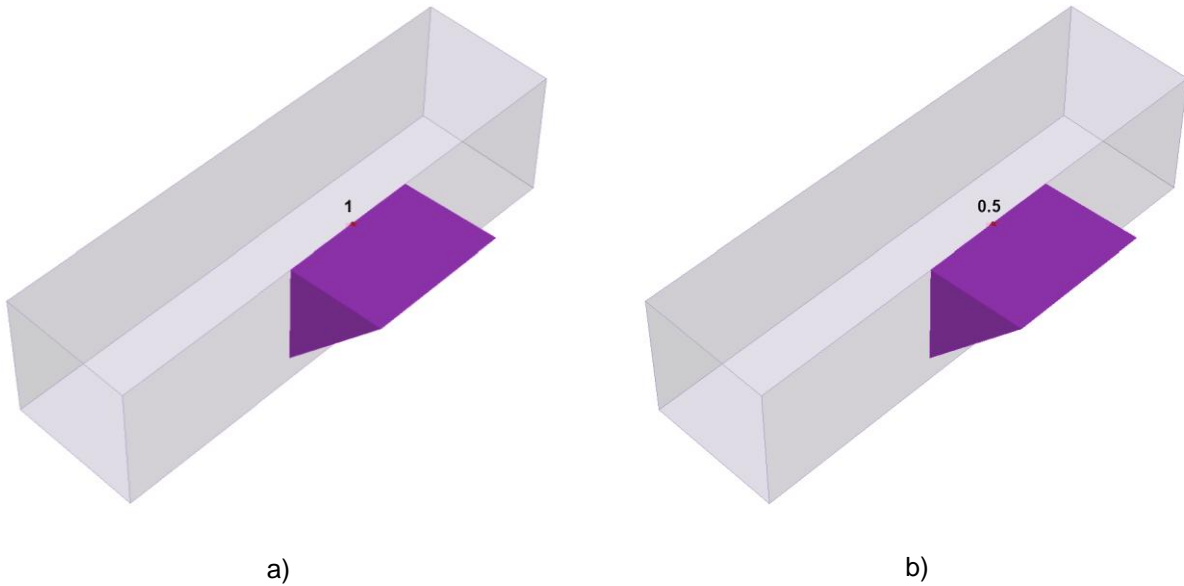

Figure 7.1: Point Load in RocTunnel3 (a) 1 MN in Stage 2 (b) 0.5 MN in Stage 3

7.2.2. Line Load

The orientation of the Line Load is applied in the unloaded block's sliding direction and properties are listed in Table 7.2.3.

Table 7.2.3: Line Load

Trend (°)	Plunge (°)	Magnitude (MN/m)	Install in Stage	Remove at Stage	Apply Stage Factor	Stage 3 Magnitude Factor
270	50	0.1	Stage 2	Never	Yes	0.5

Figure 7.2 shows the resulting geometry with a 0.1 MN/m line load applied in Stage 2 and 0.05 MN/m line load applied in Stage 3 (factored by 0.5).

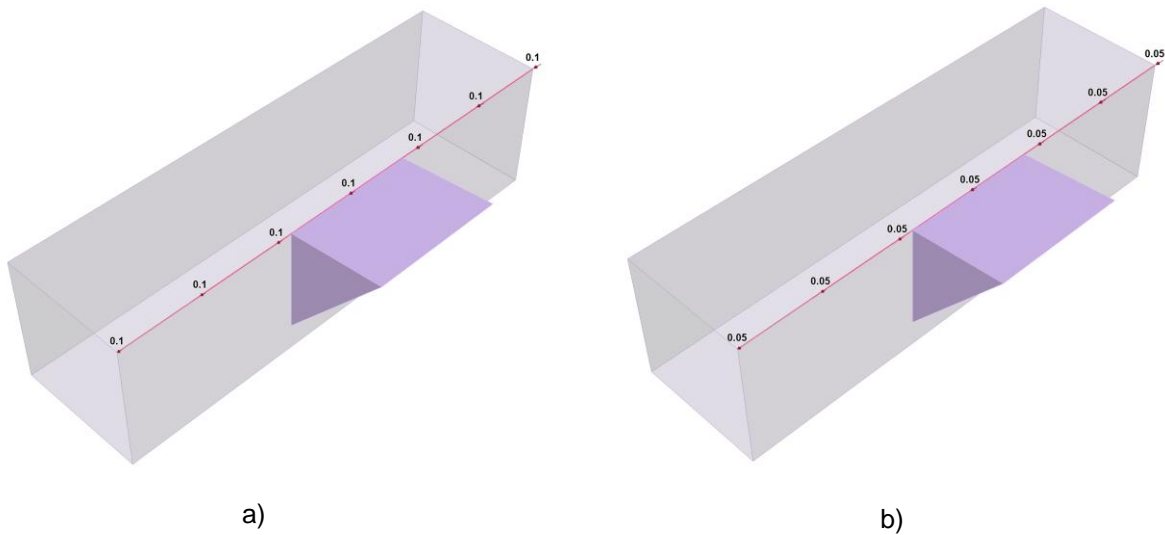

Figure 7.2: Line Load in RocTunnel3 (a) 0.1 MN/m in Stage 2 (b) 0.05 MN/m in Stage 3

7.2.3. Surface Load

The orientation of the Surface Load is applied in the unloaded block's sliding direction and properties are listed in Table 7.2.4.

Table 7.2.4: Surface Load

Trend (°)	Plunge (°)	Magnitude (MPa)	Install in Stage	Remove at Stage	Apply Stage Factor	Stage 3 Magnitude Factor
270	50	0.1	Stage 2	Never	Yes	0.5

Figure 7.3 shows the resulting geometry with a 0.1 MPa surface load applied in Stage 2 and 0.05 MPa surface load applied in Stage 3 (factored by 0.5).

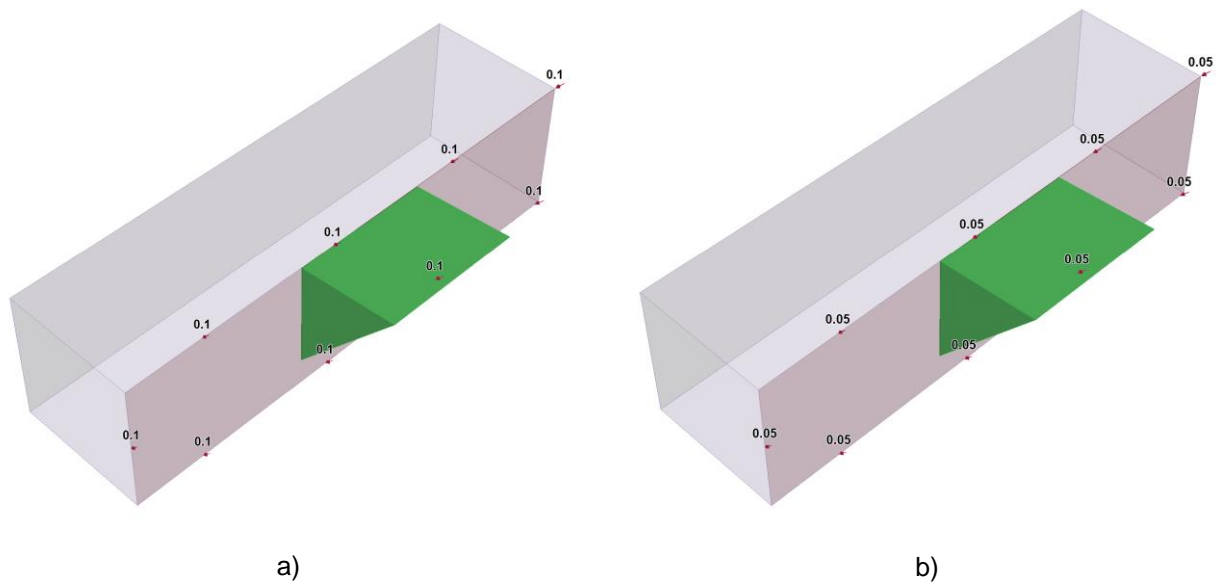

Figure 7.3: Surface Load in RocTunnel3 (a) 0.1 MPa in Stage 2 (b) 0.05 MPa in Stage 3

It is important to note that this comparison has three stages for Point, Line, and Surface Load, with Loading in each model applied starting in Stage 2. In Stage 3, a Stage Magnitude Factor of 0.5 is used.

Assuming the correctness of the Results with no external forces applied, Stage 1 (no external forces applied) is used as a benchmark to verify the results in Stages 2 and 3. Stage 2 results should account for the Magnitude Factor compared to Stage 1. Stage 3 results should account for the Stage Factor.

7.3. Analytical solution

Hand calculations are done to verify the Results. In all 3 stages for the Point Load, Line Load, and Surface Load models, the Resisting Force values are the same since the Load is applied in the Sliding Direction and should only impact the Driving Force.

Stage 1

Here correctness of results is assumed when no external forces are applied and results of this stage act as baseline values to verify results in Stages 2 and 3.

Stage 2

Point Load

Since the Point Load defined is 1 MN in the direction of Sliding Direction:

$$\begin{aligned}
 driving\ force_{stage\ 2} &= driving\ force_{stage\ 1} + magnitude \\
 &= 5.993\ MN + 1\ MN = 6.993\ MN
 \end{aligned}$$

Line Load

Since the Line Load defined is 0.1 MN/m in the direction of Sliding Direction and the known length of the edge where the Line Load is applied is 10 m:

$$\begin{aligned} driving\ force_{stage\ 2} &= driving\ force_{stage\ 1} + magnitude \times length \\ &= 5.993\ MN + \left(0.1\ \frac{MN}{m}\right)(10\ m) = 6.993\ MN \end{aligned}$$

Surface Load

Since the Surface Load defined is 0.1 MN/m² in the direction of Sliding Direction and known Excavation Face Area where the Load is applied is 80 m²:

$$\begin{aligned} driving\ force_{stage\ 2} &= driving\ force_{stage\ 1} + magnitude \times area \\ &= 5.993\ MN + (0.1\ MPa)(80\ m) = 13.993\ MN \end{aligned}$$

Stage 3

Point Load

Since the Point Load defined is 1 MN in the direction of Sliding Direction and the Stage Magnitude Factor is 0.5:

$$\begin{aligned} driving\ force_{stage\ 3} &= driving\ force_{stage\ 1} + magnitude\ factor \times magnitude \\ &= 5.993\ MN + (0.5)(1\ MN) = 6.493\ MN \end{aligned}$$

Line Load

Since the Line Load defined is 0.1 MN/m in the direction of Sliding Direction, the known length of the edge where the Load is applied is 10m and the Stage Factor is 0.5:

$$\begin{aligned} driving\ force_{stage\ 3} &= driving\ force_{stage\ 1} + magnitude\ factor \times magnitude \times length \\ &= 5.993\ MN + (0.5)\left(0.1\ \frac{MN}{m}\right)(10\ m) = 6.493\ MN \end{aligned}$$

Surface Load

Since the Surface Load defined is 0.1 MN/m² in the direction of Sliding Direction, the known Excavation Face Area where the Load is applied is 80 m² and the Stage Factor is 0.5:

$$\begin{aligned} driving\ force_{stage\ 3} &= driving\ force_{stage\ 1} + magnitude\ factor \times magnitude \times area \\ &= 5.993\ MN + (0.5)(0.1\ MPa)(80\ m) = 9.993\ MN \end{aligned}$$

7.4. Results

It is observed that analytical solution results are the same as software results in different stages.

Table 7.4.1: Driving Forces Comparison

Load Type	Driving Force Stage 2 (MN)		Driving Force Stage 3 (MN)	
	RocTunnel3	Analytical	RocTunnel3	Analytical
Point Load	6.993	6.993	6.493	6.493
Line Load	6.993	6.993	6.493	6.493
Surface Load	13.993	13.993	9.993	9.993

It is observed that resisting forces are the same across all stages as expected.

Table 7.4.2: Resisting Forces

Load Type	Resisting Force Stage 1 (MN)	Resisting Force Stage 2 (MN)	Resisting Force Stage 3 (MN)
Point Load	4.22	4.22	4.22
Line Load	4.22	4.22	4.22
Surface Load	4.22	4.22	4.22

This verifies the functioning of loads along with its staging and stage factors.

8. RocTunnel3 Verification Problem #8: Groundwater – Piezometric Surface

Groundwater Verification Problem [RocTunnel3 1.001 & UnWedge 5.019]

8.1. Problem Description

This example compares kinematic computations between UnWedge and RocTunnel3, both incorporating a Piezometric Groundwater Surface.

8.2. Geometry and Material Properties

The geometry is identical to that of Verification Problem #1. For detailed geometry, refer to Geometry and Material Properties in Verification Problem #1. A Piezometric Water Surface is defined at a height of $z = 20$ m.

Figure 8.1 and Figure 8.2 shows the resulting geometry in UnWedge and RocTunnel3, respectively.

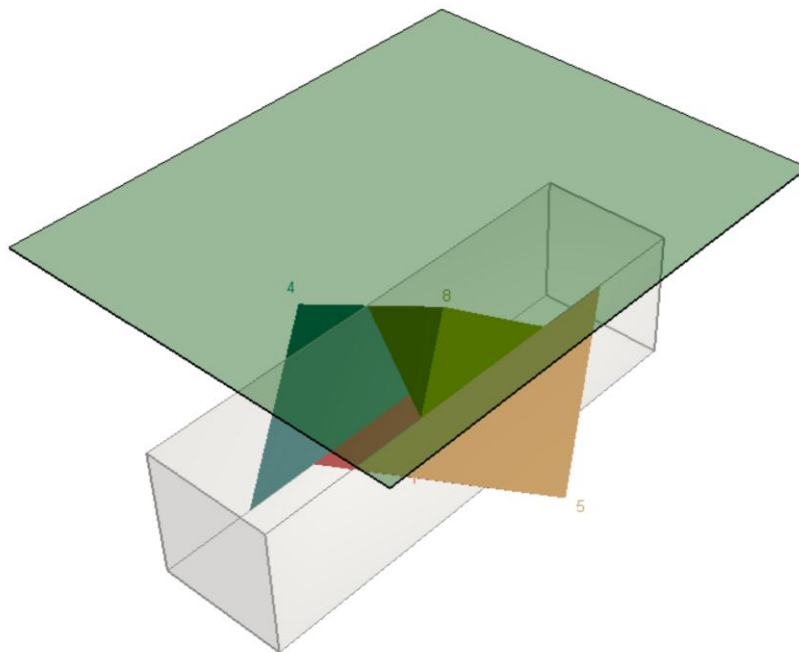

Figure 8.1: Water Surface Model in UnWedge

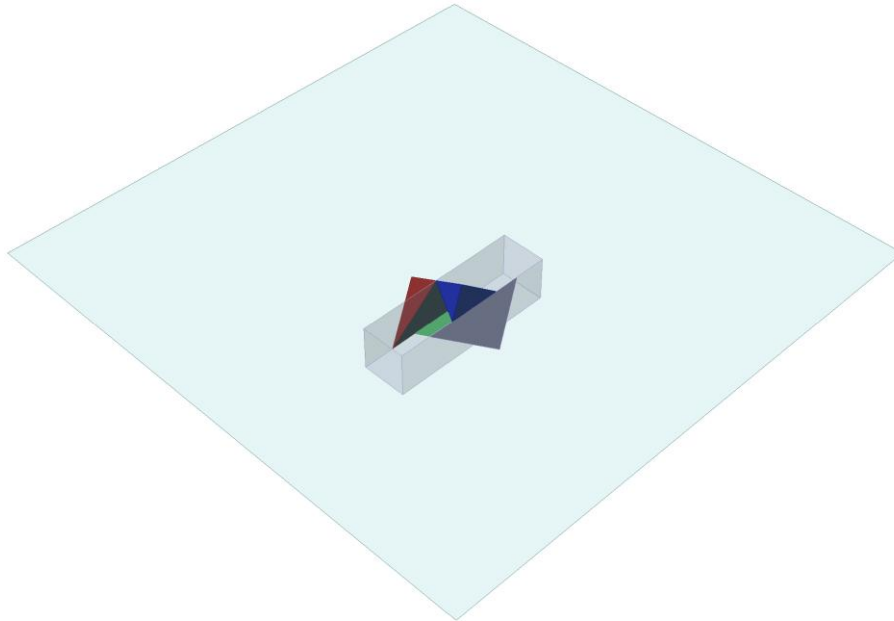

Figure 8.2: Piezometric Surface Model in RocTunnel3

There are three stages for this comparison in RocTunnel3, with the Piezometric Surface applied only in Stage 2.

Factor of Safety (FS) values in Stages 1 and 3 are expected to be the same as the FS values in Verification Problem #1 (without groundwater applied), while the driving and resisting force values in Stage 2 should be comparable to those in the UnWedge model.

Table 8.2.1: Groundwater assigned to Material 1 in different Stages

Stage 1	Stage 2	Stage 3
None	Piezometric Surface	None

8.3. Results

Four blocks are formed. First, the FS values in Stages 1 and 3 in RocTunnel3 are compared with the FS values in Verification Problem #1 (Table 8.3.1). The values are found to be the same.

Table 8.3.1: Verification Results Stage 1 and 3 in RocTunnel3 compared with Verification Problem #1

Block	RocTunnel3 Stage 1 FS	RocTunnel3 Stage 3 FS	Verification Problem #1 FS
[1] Floor Wedge	Stable	Stable	Stable
[4] Lower Left Wedge	2.922	2.922	2.922
[5] Upper Right Wedge	5.285	5.285	5.285
[8] Roof Wedge	0	0	0

Next, the Driving Force and Resistance Force Results of the blocks in Stage 2 in RocTunnel3 are compared to the UnWedge Results (Table 8.3.2). An exact agreement in computations is observed.

Table 8.3.2: Verification Results for Stage 2 in RocTunnel3 compared to UnWedge

Block	Driving Force		Resisting Force	
	RocTunnel3	UnWedge	RocTunnel3	UnWedge
[1] Floor Wedge	10.225	10.225	0	0
[4] Lower Left Wedge	19.388	19.388	0	0
[5] Upper Right Wedge	15.734	15.734	0	0
[8] Roof Wedge	6.767	6.767	0	0

This verifies both Piezometric Groundwater Surface application and its staging.

9. RocTunnel3 Verification Problem #9: Groundwater – Water Pressure Grid

Groundwater Verification Problem [RocTunnel3 1.001 & UnWedge 5.019]

9.1. Problem Description

This example compares kinematic computations between UnWedge and RocTunnel3, both incorporating a Water Pressure Grid.

9.2. Geometry and Material Properties

The geometry is identical to that of Verification Problem #1. For detailed geometry, refer to Geometry and Material Properties in Verification Problem #1. A Water Pressure Grid is defined with the properties listed in the tables below.

For UnWedge, Pore Pressure is selected as Grid Type, and Grid Interpolation method is Modified Chugh. The water pressure grid inputs are listed in Table 9.2.1.

Table 9.2.1: 2D Water Pressure Grid Input Values in UnWedge

Point	X (m)	Y (m)	Pore Pressure (MPa)
1	20	20	0
2	0	20	0
3	-20	20	0
4	20	0	0.1962
5	0	0	0.1962
6	-20	0	0.1962
7	20	-20	0.3924
8	0	-20	0.3924

9	-20	-20	0.3924
---	-----	-----	--------

To create the Water Pressure Grid in RocTunnel3, 3D was chosen as Dimension, Interpolation Method was set to Hybrid and Type was chosen as Pore Pressure. Table 9.2.2 outlines the coordinates inputted.

Table 9.2.2: 3D Water Pressure Grid Input Values in RocTunnel3

Point	X (m)	Y (m)	Z (m)	Pore Pressure (MPa)
1	20	-20	20	0
2	0	-20	20	0
3	-20	-20	20	0
4	20	-20	0	0.1962
5	0	-20	0	0.1962
6	-20	-20	0	0.1962
7	20	-20	-20	0.3924
8	0	-20	-20	0.3924
9	-20	-20	-20	0.3924
10	20	20	20	0
11	0	20	20	0
12	-20	20	20	0
13	20	20	0	0.1962

14	0	20	0	0.1962
15	-20	20	0	0.1962
16	20	20	-20	0.3924
17	0	20	-20	0.3924
18	-20	20	-20	0.3924

The figures below show the resulting geometry.

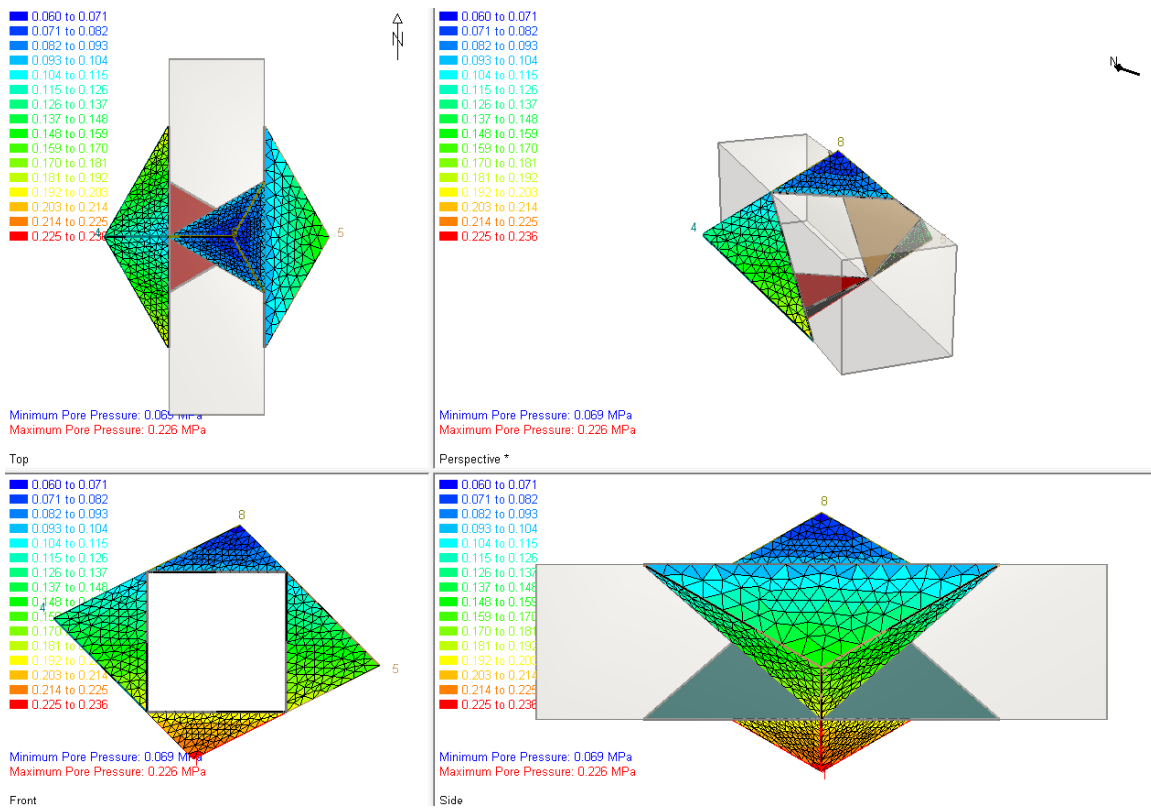

Figure 9.1: Water Pressure Grid Model in UnWedge

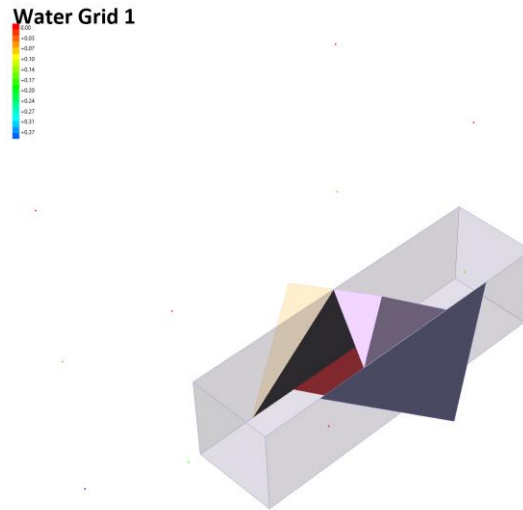

Figure 9.2: Final Water Pressure Grid Model in RocTunnel3

It is important to note that there are three stages for this comparison in RocTunnel3, with the Water Pressure Grid applied only in Stage 2.

Factor of Safety (FS) values in Stages 1 and 3 are expected to be the same as the FS values in Example 1 (without groundwater applied). The Driving and Resisting Force values in Stage 2 are comparable to those in the UnWedge model. Values in Stage 2 are expected to be the same as the Driving and Resisting Force values in Verification Problem #8 Stage 2 since similar groundwater conditions are created in this model (i.e., hydrostatic).

Table 9.2.3: Groundwater assigned to Material 1 In different Stages

Stage 1	Stage 2	Stage 3
None	Water Grid 1	None

9.3. Results

Four blocks are formed. First, the FS values in Stages 1 and 3 in RocTunnel3 are compared with the FS values in Verification Problem #1 (Table 9.3.1). It is observed that the values are the same as expected.

Table 9.3.1: Verification Results comparing Stages 1 and 3 with Verification Problem #1

Block	Verification Problem #1 Stage 1 FS	RocTunnel3 FS Stage 1	RocTunnel3 FS Stage 3
[1] Floor Wedge	Stable	Stable	Stable

[4] Lower Left Wedge	2.922	2.922	2.922
[5] Upper Right Wedge	5.285	5.285	5.285
[8] Roof Wedge	0	0	0

Next, the Driving Force and Resistance Force values of the blocks in Stage 2 computed with RocTunnel3 are compared with the UnWedge model, and Stage 2 in Verification Problem #8 (Table 9.3.2). Exact agreement in computations is observed.

Table 9.3.2: Verification Results for Stage 2 in RocTunnel3 compared to UnWedge

Block	Driving Force (MN)			Resisting Force (MN)		
	RocTunnel3	UnWedge	Stage 2 – Verification Problem #8	RocTunnel3	UnWedge	Stage 2 – Verification Problem #8
[1] Floor Wedge	10.225	10.225	10.225	0	0	0
[4] Lower Left Wedge	19.388	19.388	19.388	0	0	0
[5] Upper Right Wedge	15.734	15.734	15.734	0	0	0
[8] Roof Wedge	6.767	6.767	6.767	0	0	0

This verifies both Water Pressure Grid application and its staging.

10. RocTunnel3 Verification Problem #10: Bolts

Support Verification Problem [RocTunnel3 1.001]

10.1. Problem Description

This section presents several verification problems of different failure modes of bolts in RocTunnel3.

Users can select from a list of pre-defined different types of bolts, choose to use either shear strength or tensile strength of bolts, and select to apply bolt orientation efficiency factor. Depending on the length, orientation, location, and material properties assigned to the bolt, different failure modes can be propagated in bolts. These failure modes include tensile, stripping, pullout, and shear failures. In this example, all four types of failure modes are verified with respect to the analytical solution.

10.2. Geometry and Material Properties

The geometry is identical to that of Verification Problem #1. For detailed geometry, refer to Geometry and Material Properties in Verification Problem #1. Measured Joints Data is modified to create the geometry for this model. The Table 10.2.1 outlines the modified Measured Joint orientations in the model in RocTunnel3 after importing the model.

Table 10.2.1: Measured Joints Orientations

Joint	Dip (°)	Dip Direction (°)	X (m)	Y (m)	Z (m)	Radius (m)
1	50	270	10	0	2	13
2	0	0	10	0	8	13
3	90	0	10	-5	2	13
4	90	0	10	5	2	13

In this example, grouted dowel is employed for all verification models as all four failure modes can be simulated with this bolt type.

The Bolt force model can be applied in two different force application methods, known as Active and Passive. Active support is assumed to act in such a manner as to decrease the driving force in the FS calculation. Tensioned cables or rock bolts, which exert a force on the wedge before any movement has taken place, are considered Active support. Passive support, however, is assumed to increase the resisting force provided by shear restraint. Both Active and Passive bolt models are tested for each failure mode carried by separate cases.

A single Grouted Dowel is installed at the center of the sloped surface of the wedge, penetrating the joint. To induce different failure modes in the grouted dowel, it is necessary to manipulate both the geometry and its properties. It is also important to note that there are three stages for this comparison in this model, and the bolt is only applied in Stage 2. The FS values in Stages 1 and 3 are expected to be the same as the FS values in Verification Problem #1 (no external force applied) and Stage 2 to be the same as the analytical values. The bolt properties and geometries are listed in Table 10.2.2.

Table 10.2.2: Bolt Properties and Geometry

Failure Modes		Tensile	Stripping	Pullout	Shear
Bolt Geometry	Bolt Length (m)	10	10	5	10
	Trend/Plunge (°)	90 / 0			
	Projection	Right Surface			
Support Type		Grouted Dowel			
General Bolt Properties	Force Application	Active and Passive			
	Bolt Orientation Efficiency	Cosine Tension/Shear			
	Tensile capacity (MN)	0.24			
	Use Shear Capacity	False			True
	Shear Capacity (MN)	N/A			0.1
	Use Compression Capacity	False			
Pullout and Stripping Bolt Properties	Plate Capacity (MN)	0.1			
	Bond Strength (MN/m)	0.1			
	Material Dependent	False			
	Use Percent of Length	True			
	Percent of Length (%)	100	80	100	100

The figure below shows the resulting geometry.

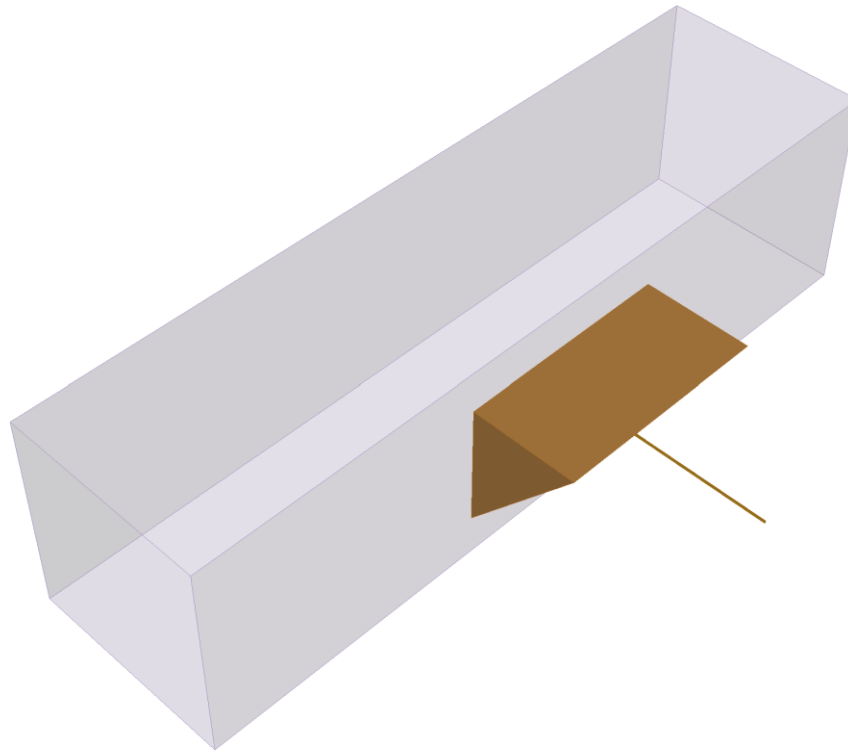

Figure 10.1: Bolt Model in RocTunnel3

10.3. Problem Description

This section presents the calculation of resultant resisting and driving forces induced at the sliding surface with the presence of the bolt. Based on the bolt properties and geometry setup for the four cases, the bolt loading capacity (C_L) is calculated as follows:

$$(10.1) \quad C_L = E \times \min(F_1, F_2, F_3)$$

Where:

$$\text{Pullout: } F_1 = B_s L_a$$

$$\text{Tensile: } F_2 = T$$

$$\text{Stripping: } F_3 = P + B_s L_w$$

B_s is bond strength

L_a is anchorage length (bonded length of dowel embedded in rock beyond wedge)

T is tensile capacity

P is plate capacity

L

L_w is wedge length (bonded length of dowel within wedge)

E is efficiency factor

The bolt force vector (B) is calculated as follows:

$$B = C_L \hat{e} \quad (10.2)$$

Where:

\hat{e} is the unit direction vector of the bolt.

Considering the weight of the wedge (W) and the bolt force vector, the total normal force on joint (N) is calculated as follows:

$$N = (W\hat{g} + B) \cdot \hat{n} \quad (10.3)$$

Where:

\hat{n} is the inward (into the wedge) normal of the joint

\hat{g} is the gravity direction (0, 0, -1)

Using N , joint shear strength (τ) is calculated based on the Mohr-Coulomb strength criterion as follows:

$$\tau = c + \frac{N}{a} \tan \phi \quad (10.4)$$

Where:

c is the cohesion of the joint

a is the area of the joint

ϕ is the friction angle of the joint

Depending on the force application setting between active and passive, the shear component of the force applied by the bolt is added to the resisting force and subtracted from the driving force, respectively.

Thus, the active and passive resisting forces are calculated as follows:

$$\text{active resisting force} = \tau \cos \theta \quad (10.5)$$

$$\text{passive resisting force} = \tau \cos \theta - (B \cdot \hat{s}) \quad (10.6)$$

Where:

θ is the angle between the sliding direction and joint

\hat{s} is the sliding direction

Moreover, active and passive driving forces are calculated as follows:

$$\text{active driving force} = (W\hat{g} + B) \cdot \hat{s} \quad (10.7)$$

$$\text{passive driving force} = W\hat{g} \cdot \hat{s} \quad (10.8)$$

10.4. Results

Table 10.4.1 compares bolt results in various failure modes.

Table 10.4.1: Stage 2 Driving and Resisting Forces Comparison

Analysis number	Case	RocTunnel3 Vs. Analytical	min (F1, F2, F3) (MN)	Driving Force	Resisting Forces
1	Tensile - Active	RocTunnel3	F2	3.024	2.298
		Analytical	F2	3.024	2.298
2	Tensile - Passive	RocTunnel3	F2	3.124	2.398
		Analytical	F2	3.124	2.398
3	Stripping - Active	RocTunnel3	F3	3.038	2.285
		Analytical	F3	3.038	2.285
4	Stripping - Passive	RocTunnel3	F3	3.124	2.371
		Analytical	F3	3.124	2.371
5	Pullout - Active	RocTunnel3	F1	3.045	2.279
		Analytical	F1	3.045	2.279
6	Pullout - Passive	RocTunnel3	F1	3.1239	2.385
		Analytical	F1	3.1239	2.385
7	Shear - Active	RocTunnel3	0.1 (Shear)	3.0239	2.1995
		Analytical	0.1 (Shear)	3.0239	2.1995

8	Shear - Passive	RocTunnel3	0.1 (Shear)	3.1239	2.2995
		Analytical	0.1 (Shear)	3.1239	2.2995

It is also observed that Stage 1 and Stage 3 Driving and Resisting Force values are the same throughout 8 analyses, which is the expected result as no external forces are applied in those stages.

As exact agreement in expected and observed values is found, this verifies bolts and their staging in RocTunnel3.

11. RocTunnel3 Verification Problem #11: Successive Failure Verification Problem

Successive Failure [RocTunnel3 1.001 & UnWedge 5.019]

11.1. Problem Description

Assuming the correctness of safety factor computations for an individual block, this section will detail the verification of the Successive Analysis of block failure.

11.2. Geometry and Material Properties

The geometry is identical to that of Verification Problem #1. For detailed geometry, refer to Geometry and Material Properties in Verification Problem #1. Table 11.2.1 outlines the modified Measured Joint orientations in the model in RocTunnel3 after importing the model.

Table 11.2.1: Measured Joints Data in RocTunnel3

Dip (°)	Dip Direction (°)	X (m)	Y (m)	Z (m)	Radius (m)
35	270	12	0	5	17
10	270	12	0	10	22
90	0	12	-9	5	27
90	0	12	9	5	27
90	90	12	0	5	23
90	90	16	0	5	23

Only one stage is defined in RocTunnel3.

11.3. Results

When the model is run with Successive Failure Analysis enabled, four blocks are formed.

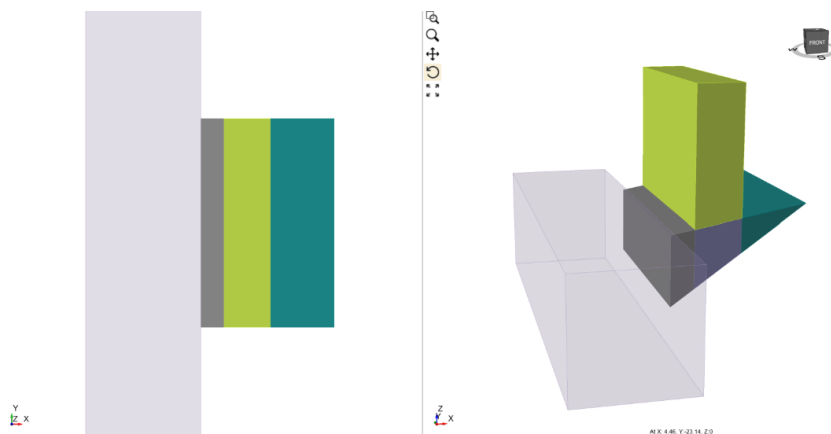

Figure 11.1: Blocks in RocTunnel3

Relying on the validity of the block engine, it is observed that in Figure 11.2, the block on the tunnel surface that is unobstructed (block 3) fails in the first iteration. The middle block (block 4), obstructed by block 3, fails in the second iteration. Blocks 1 and 2, obstructed by block 3 and 4, fails in the third iteration.

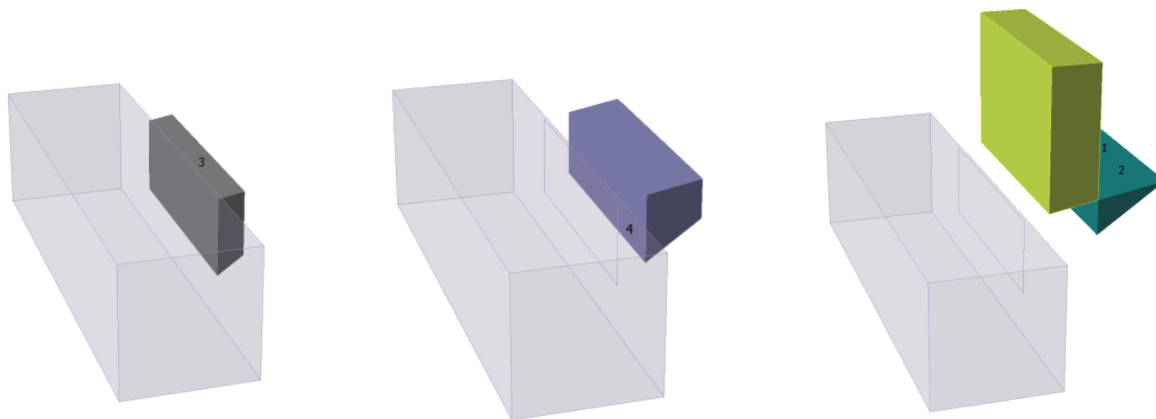

Figure 11.2: Block 3 fails in Iteration 1, Block 4 in Iteration 2, and Block 1 and 2 in Iteration 3

RocTunnel3 results are presented in Figure 11.3.

ID	Color	Removable ?	FS < Design FOS?	Failure Iteration	Factor of Safety	Volume (m ³)	Weight (MN)	Driving Force (MN)	Resisting Force (MN)	Failure Mode	Sliding Direction Trend (°)	Sliding Direction Plunge (°)	Failure Depth (m)
1	Green	<input checked="" type="checkbox"/>	<input checked="" type="checkbox"/>	3	0	814.61	21.99	21.99	0	Falling	0	90	16.48
2	Blue	<input checked="" type="checkbox"/>	<input checked="" type="checkbox"/>	3	0.52	144.93	3.91	2.24	1.17	Sliding	270	35	0
3	Grey	<input checked="" type="checkbox"/>	<input checked="" type="checkbox"/>	1	0.52	198.86	5.37	3.08	1.6	Sliding	270	35	8.28
4	Dark Blue	<input checked="" type="checkbox"/>	<input checked="" type="checkbox"/>	2	0.52	284.56	7.68	4.41	2.29	Sliding	270	35	0

Figure 11.3: RocTunnel3 Successive Failure Analysis Results

This verifies Successive Failure Analysis in RocTunnel3.

12. References

Goodman, R.E. and Shi, G. (1985), "Block Theory and Its Application to Rock Engineering", Prentice-Hall, London.